

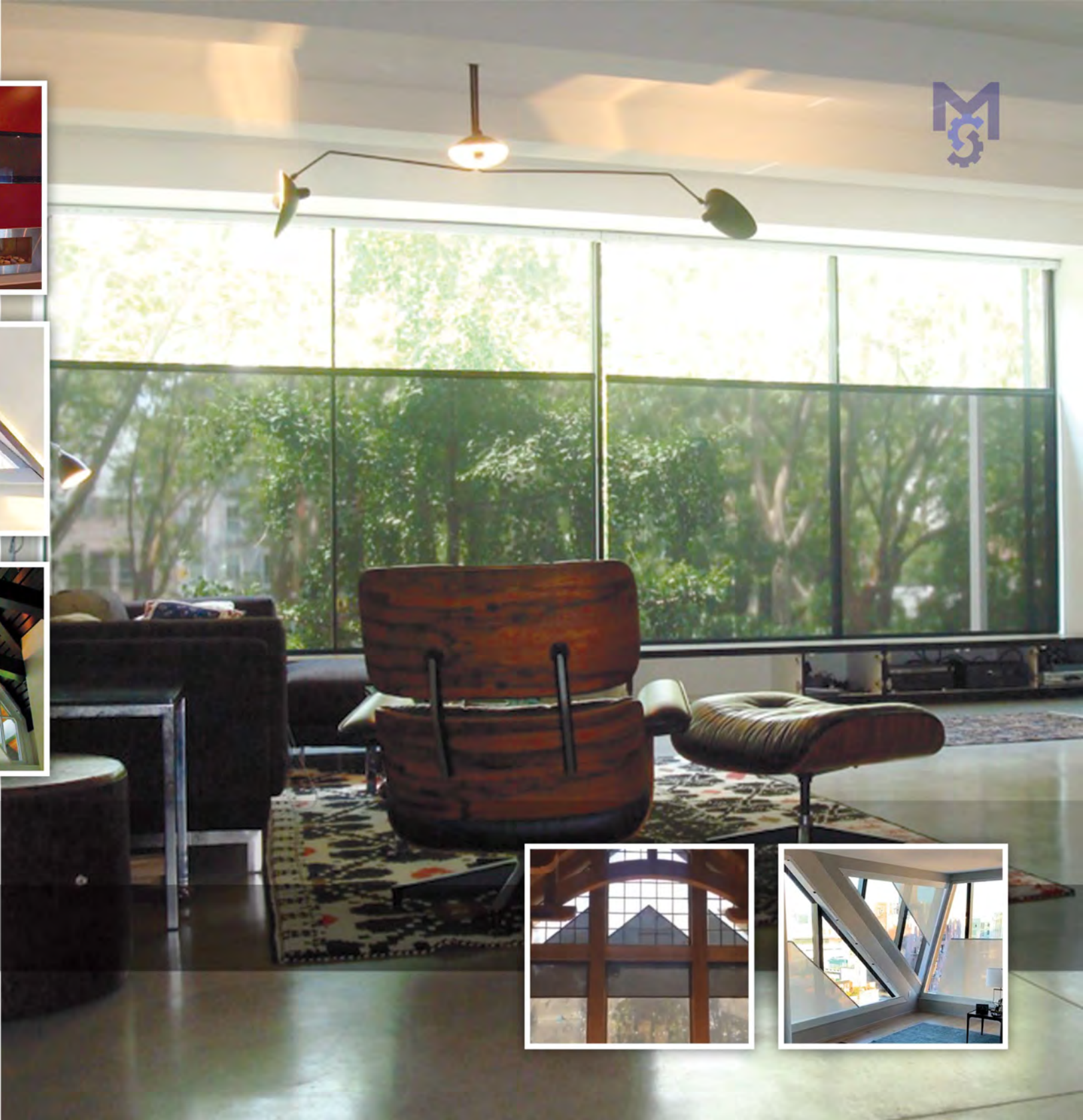

Specialty Systems Guide

INNOVATIONS IN SHADING SYSTEMS

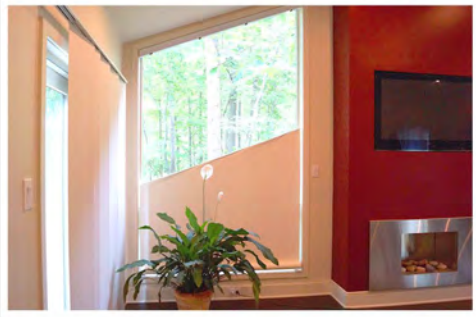

Innovations
IN SYMMETRY





Innovative PRODUCTS

ROLLER SHADES



BLINDS

DRAPERY



HONEYCOMB

ROMANS



SKYLIGHTS

BOTTOM-UP



SPECIALTY

ANGLED ROLLER SHADES



Years of research and development by our shade craftsmen have resulted in an award winning bottom-up, angled, roller shade system. The shades fully retract to expose the glass and architectural features of your angled, trapezoid, and pyramid shaped windows. They are truly a one-of-a-kind solution.



BATTERY SIZE LIMITS - Limited Availability. *Contact customer service for details.*
WIRED SIZE LIMITS: 132" x 144" *Larger Sizes May Be Available*

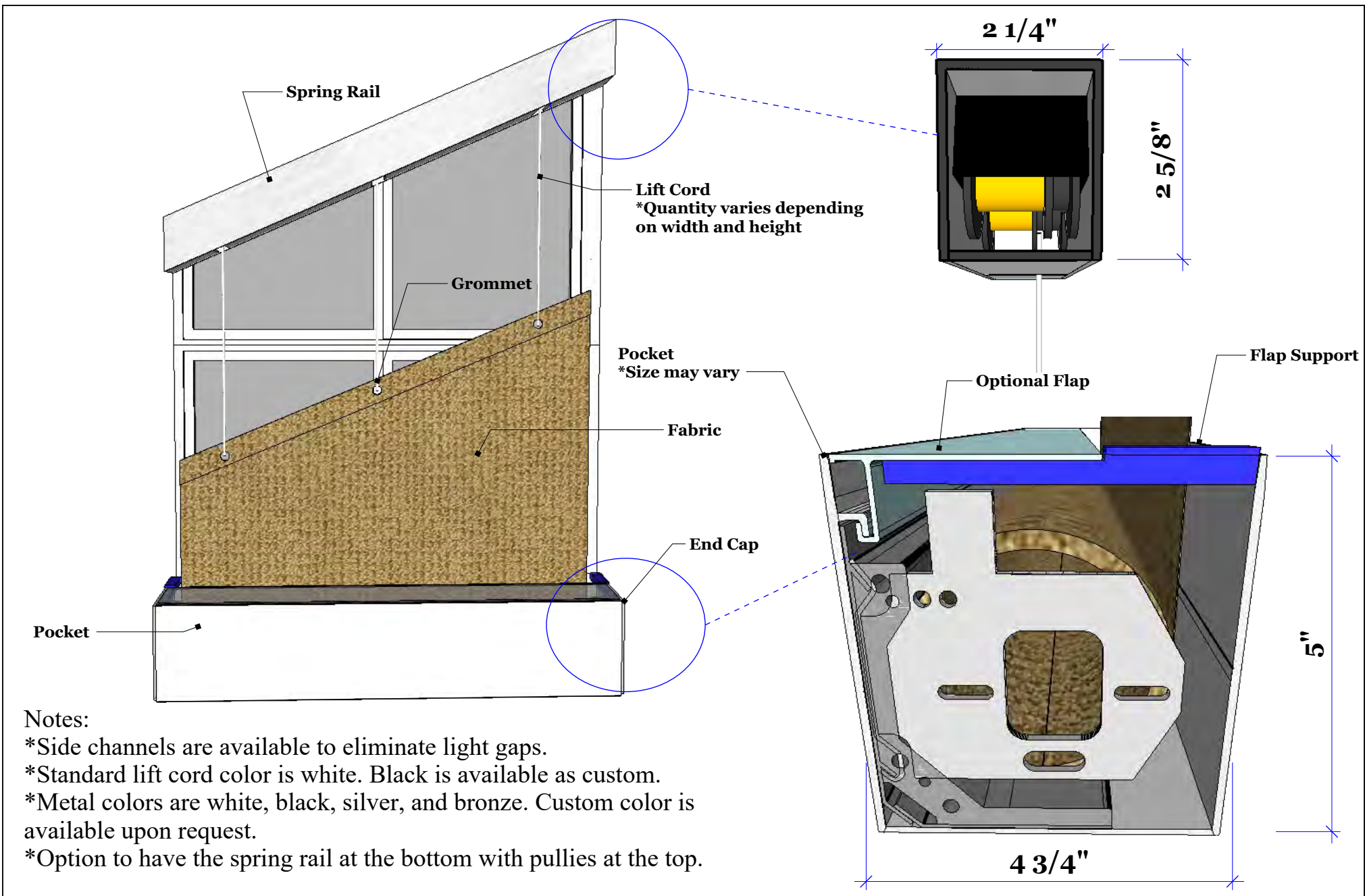

Notes:

- *Side channels are available to eliminate light gaps.
- *Standard lift cord color is white. Black is available as custom.
- *Metal colors are white, black, silver, and bronze. Custom color is available upon request.
- *Option to have the spring rail at the bottom with pulleys at the top.

Angled Bottom-Up Shades



REVISIONS		
	MM/DD/YY	REMARKS
1	---/---/---	...
2	---/---/---	...
3	---/---/---	...
4	---/---/---	...
5	---/---/---	...

A 01

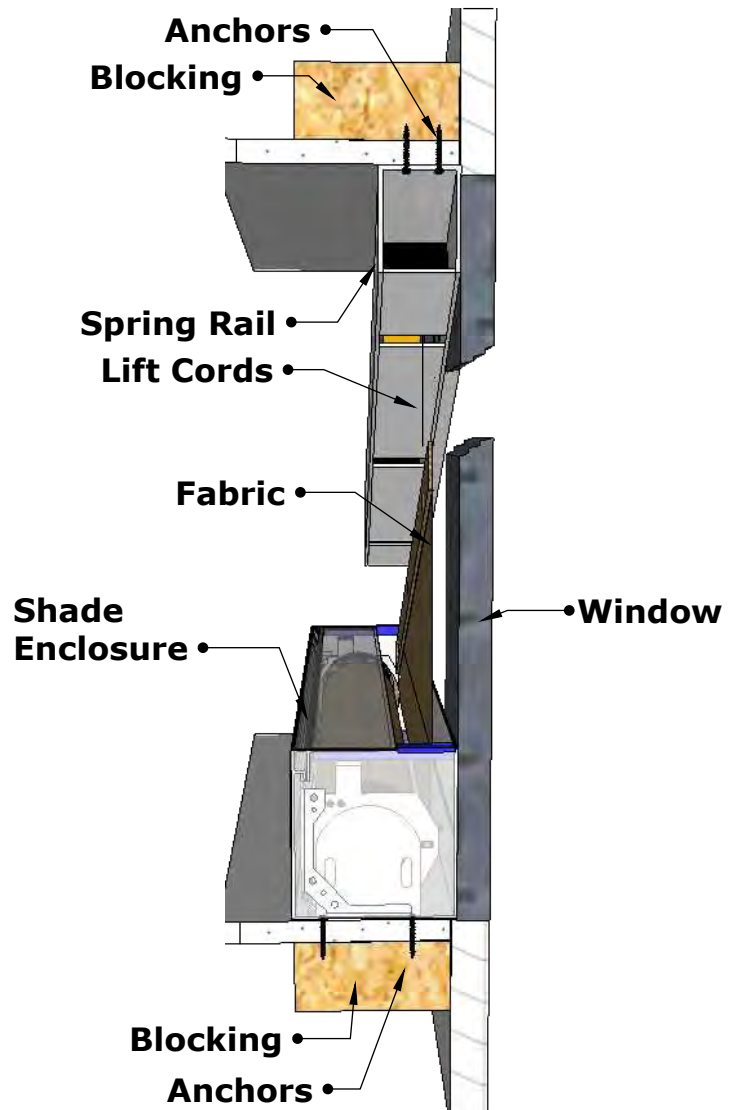

Inside Mount
Typical

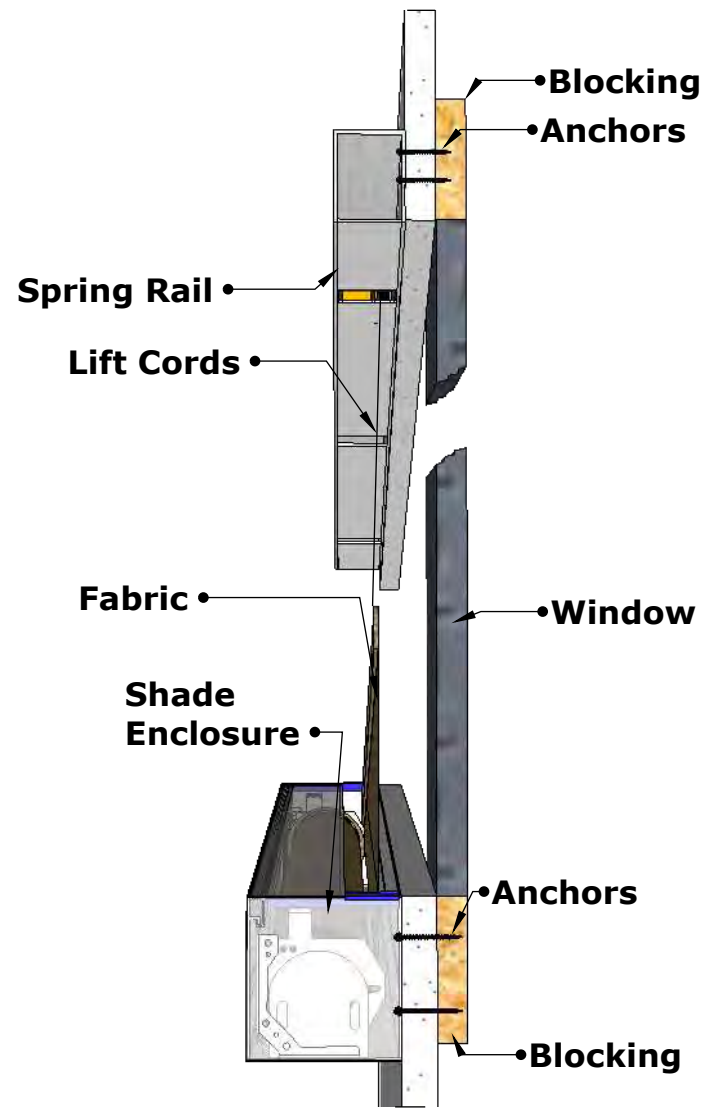

Outside Mount
Typical

ANGLED CELLULAR SHADES

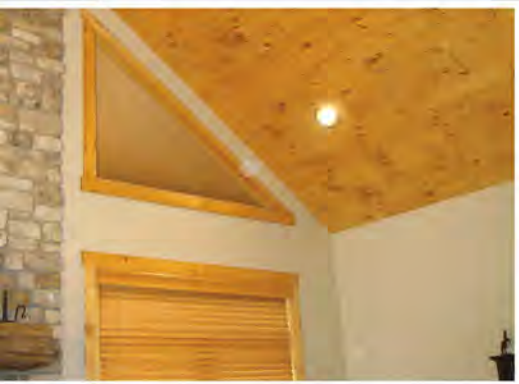

Our angled motorized cellular shades are hand crafted to custom fit each unique window. The system mounts at the top angled portion of the opening, fully retracting to expose the architectural features of your window. They are energy efficient in both cold and warm climates. Their honeycomb-like design traps air in distinct pockets, providing insulation to lower your energy consumption and assist with the efficiency of your home. Fabric options range from sheer to blackout. Cellular shades are an optimal choice for an energy focused design.



BATTERY SIZE LIMITS: 60" x 60" *Larger Sizes May Be Available*

WIRED SIZE LIMITS: 60" x 60" *Larger Sizes May Be Available*

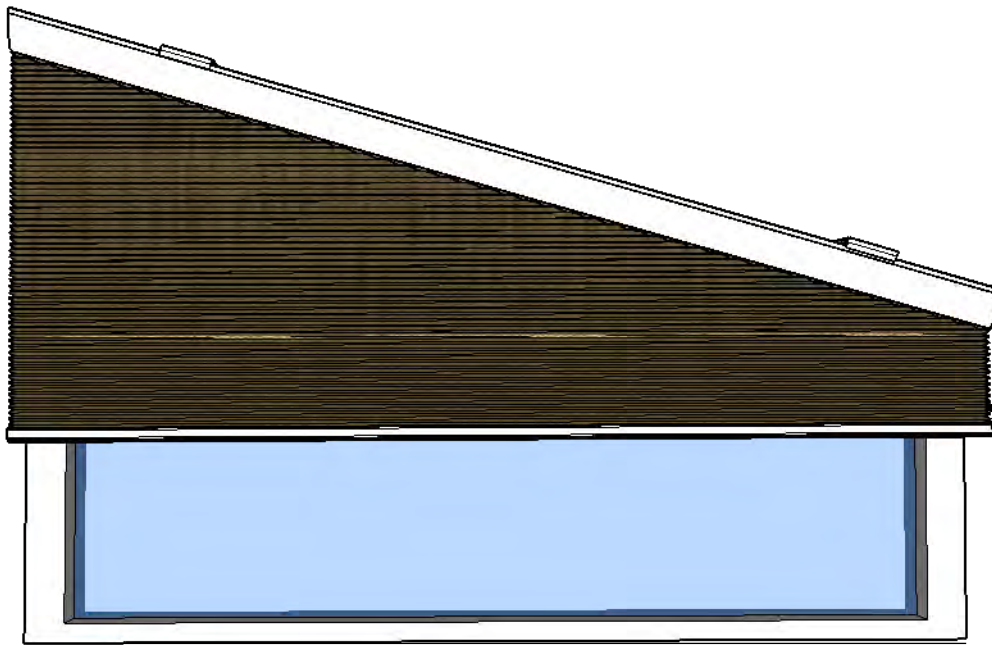

Varies Based on Model

Single Cell Fabric Only

Concealed weighted rod

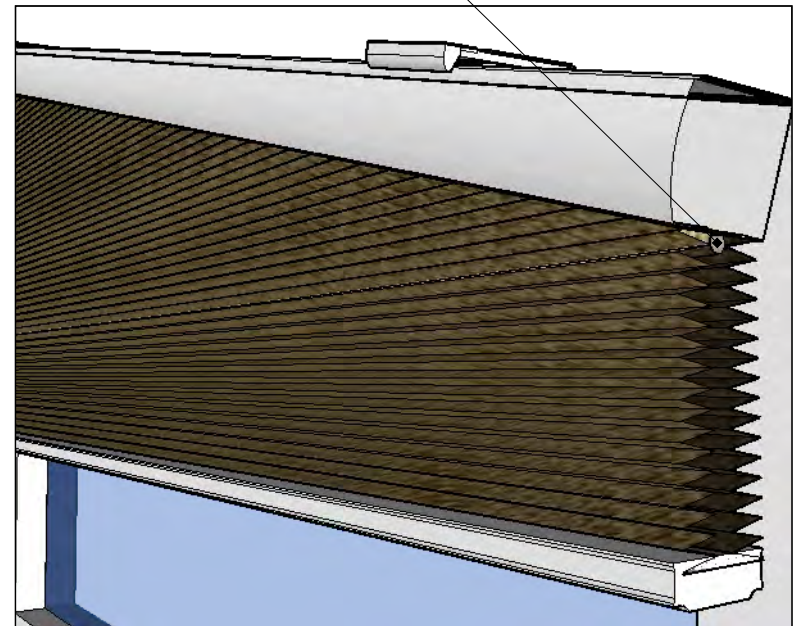

Note - Headrail endcaps are not available on angled honeycomb shades.

Angled Honeycomb Shades



REVISIONS		
	MM/DD/YY	REMARKS
1	--/--/--	...
2	--/--/--	...
3	--/--/--	...
4	--/--/--	...
5	--/--/--	...

STRAIGHT BOTTOM-UP ROLLER SHADES

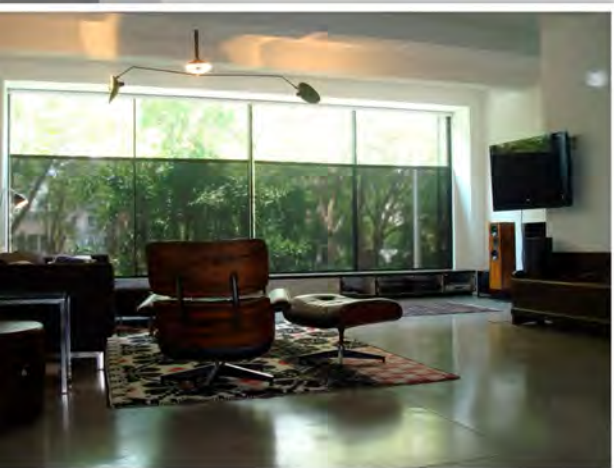
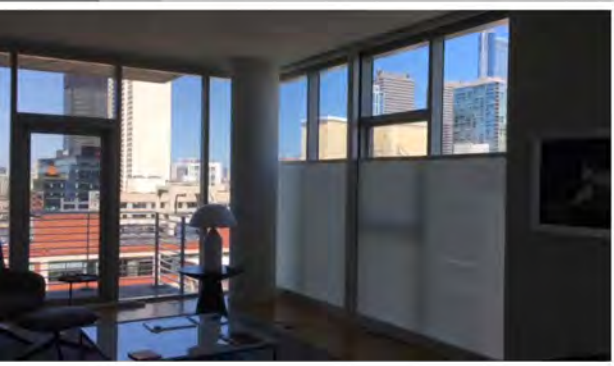

Bottom-up shades provide privacy while allowing natural light to illuminate the room. They deliver function to areas where privacy is a factor and furnish a beautiful aesthetic.



BATTERY SIZE LIMITS - Limited Availability. *Contact customer service for details.*

WIRED SIZE LIMITS: 180" x 180" *Larger Sizes May Be Available*

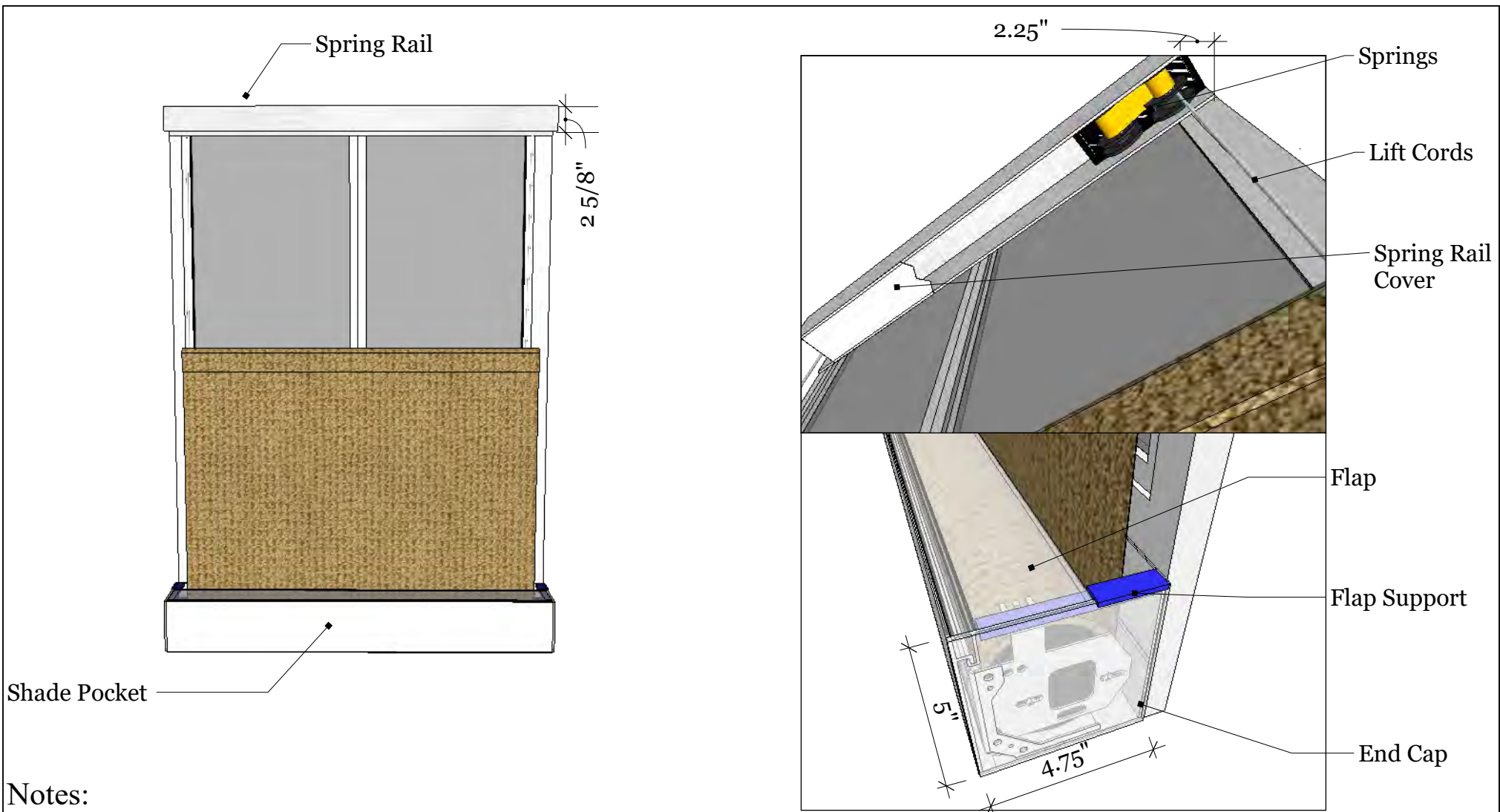

Notes:

- *Side channels are available to eliminate light gaps and hide lift cords,
- *Additional lift cords may be required on shades over 72" wide.
- *Standard lift cord color is white. Black is available as custom.
- *Metal colors are white, black, silver, and bronze. Custom color is available upon request.
- *Option to have the spring rail at the bottom and pulley at the top.

Straight Bottom-Up Shades



REVISIONS		
	MM/DD/YY	REMARKS
1	---/---/---	...
2	---/---/---	...
3	---/---/---	...
4	---/---/---	...
5	---/---/---	...

A 01

SKYLIGHT SHADES



Motorized skylight shades are available in a variety of different systems including our exclusive cellular skylight system featuring one of the only “no visible cord” skylight shades in the industry.



Motorized skylight “**rolling shades**” are available in a wide range of color and opacity options including sunscreens, light filtering, and blackout fabrics. Our sunscreen fabrics block up to 99% of UV and heat without impairing the view of the room.



Motorized skylight “**cellular shade**” systems allow many fabric options. You can provide a pattern and color from any major shade manufacturer, send us your existing shades, or choose from our collection of fine fabrics.



SKYLIGHT ROLLING/ROLLER SHADES

BATTERY SIZE LIMITS: Limited Availability. *Contact customer service for details.*

WIRED SIZE LIMITS: 96" x 120" *Larger Sizes May Be Available*



SKYLIGHT CELL SHADES

BATTERY SIZE LIMITS: 60" x 60" *Larger Sizes May Be Available*

WIRED SIZE LIMITS: 60" x 60" *Larger Sizes May Be Available*

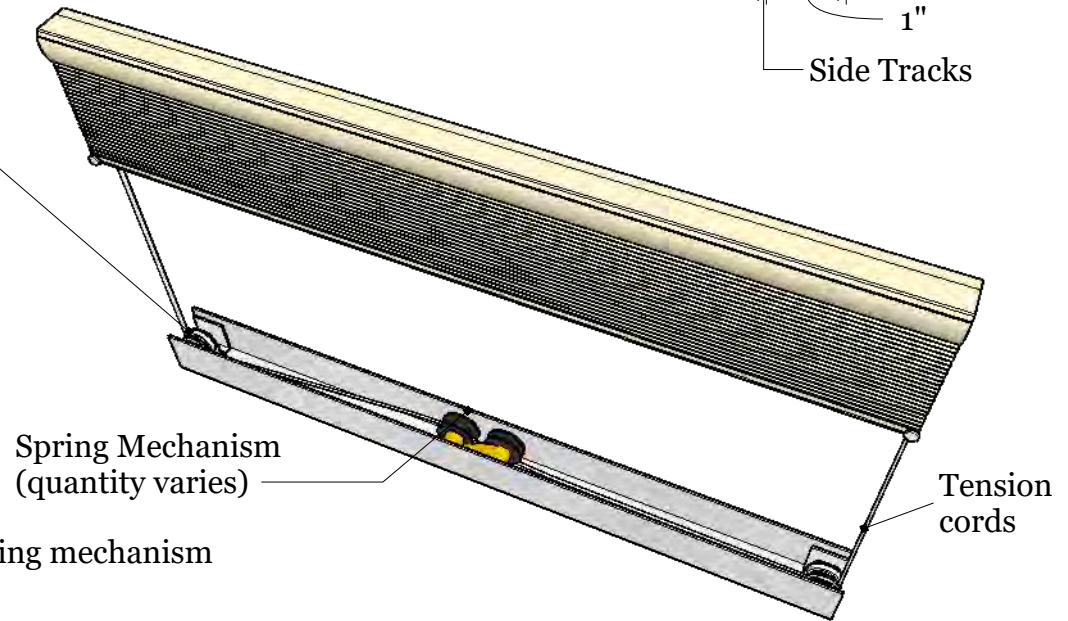
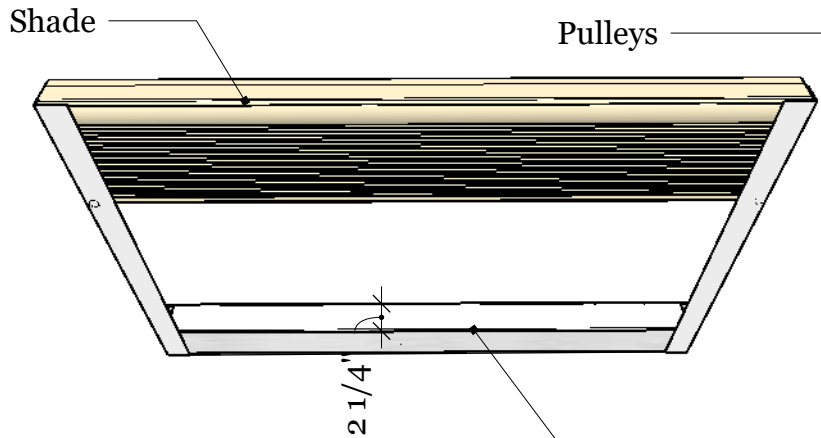
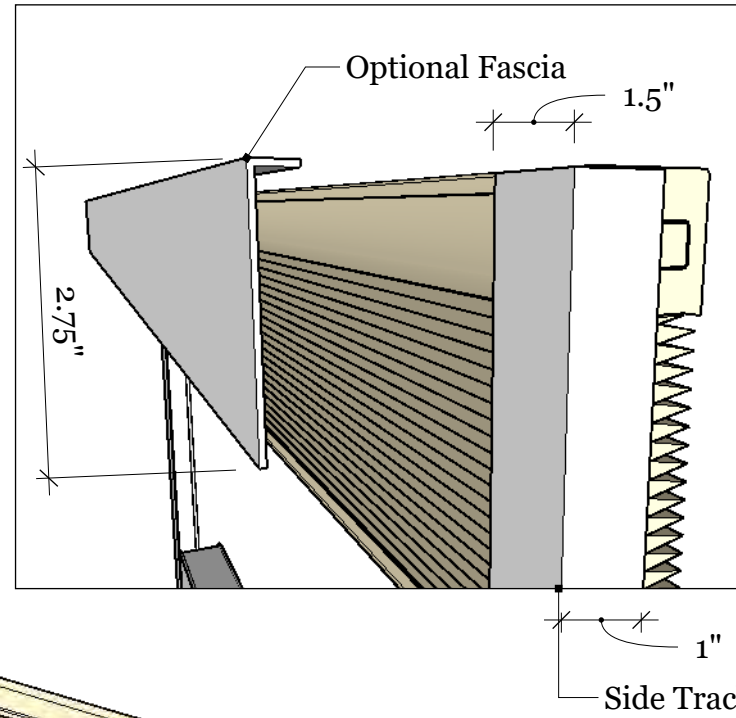
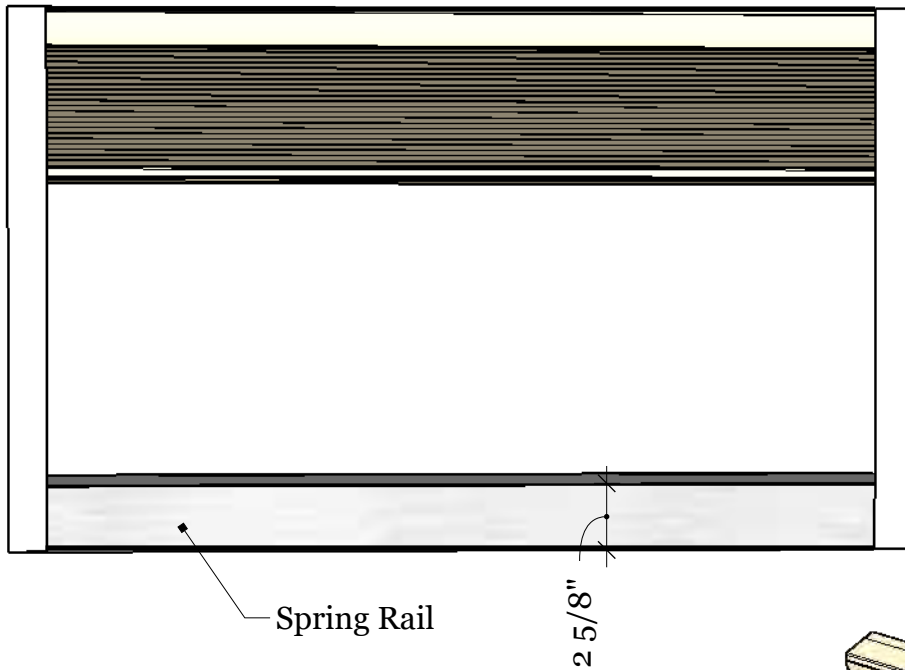

Note: Spring rail, side tracks, and optional fascia is available in white, black, bronze and silver

Honeycomb/Cell Skylight Shade



REVISIONS		
	MM/DD/YY	REMARKS
1	--/--/--	...
2	--/--/--	...
3	--/--/--	...
4	--/--/--	...
5	--/--/--	...

A 01

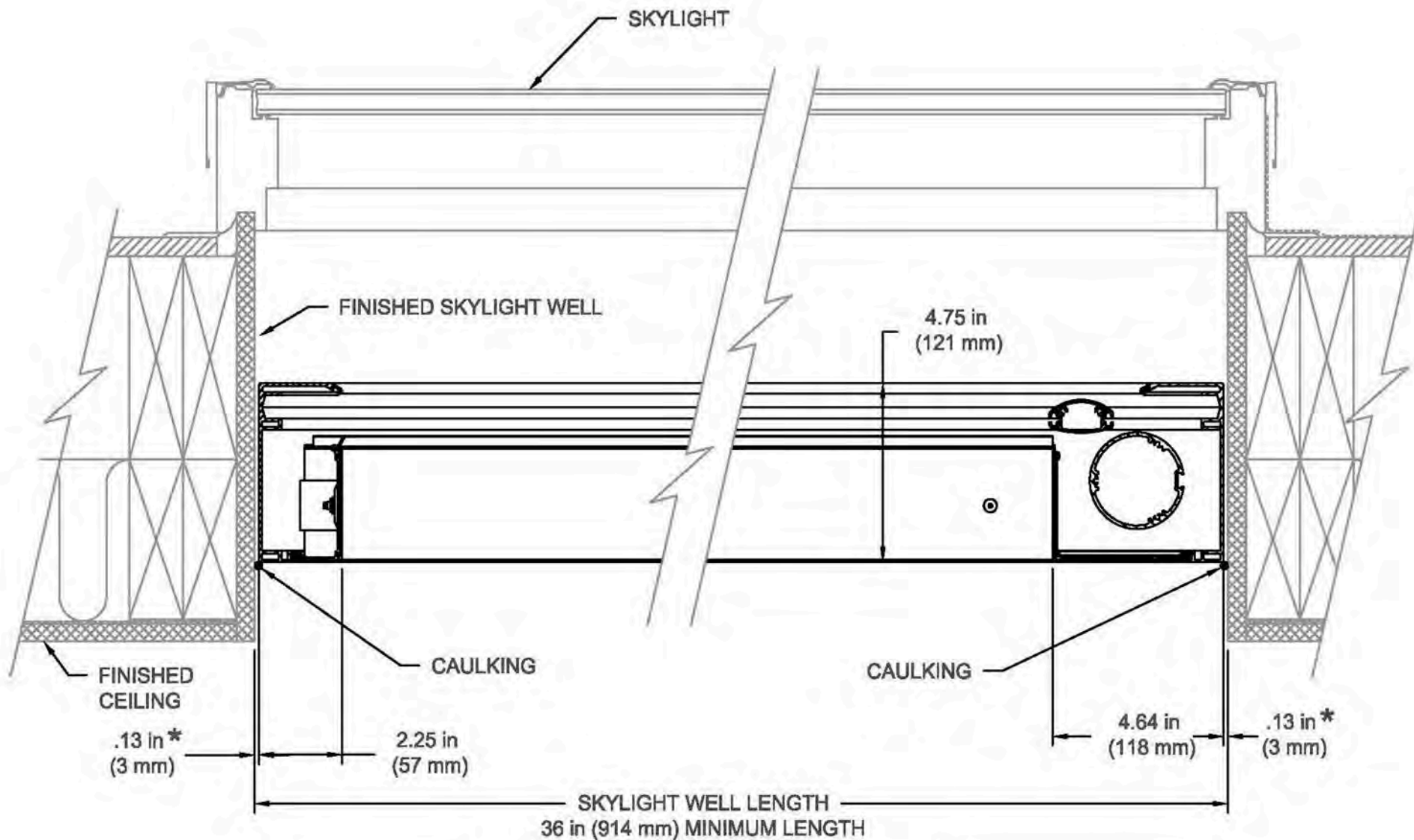

* DEDUCTION FOR INSIDE MOUNT 1/8" ALL SIDES *

Roller Skylight

Note - Alternative configurations are available



REVISIONS

	MM/DD/YY	REMARKS
1	___/___/___	...
2	___/___/___	...
3	___/___/___	...
4	___/___/___	...
5	___/___/___	...

01

A

ARCHED SHADES



Arched shades are hand crafted by our shade artisans to custom fit the curvatures of your window. The shade rises from the bottom to fully cover the radius of the opening.

The shades feature a vast collection of soft, touchable fabrics with intriguing textures, weaves, and colors ranging from traditional to contemporary.



ARCHED ROLLING / ROLLER SHADES

BATTERY SIZE LIMITS: Limited Availability. *Contact customer service for details.*

WIRED SIZE LIMITS: 84" x 84" *Larger Sizes May Be Available*



ARCHED CELL / HONEYCOMB SHADES

BATTERY SIZE LIMITS: 48" x 48" *Larger Sizes May Be Available*

WIRED SIZE LIMITS: 48" x 48" *Larger Sizes May Be Available*

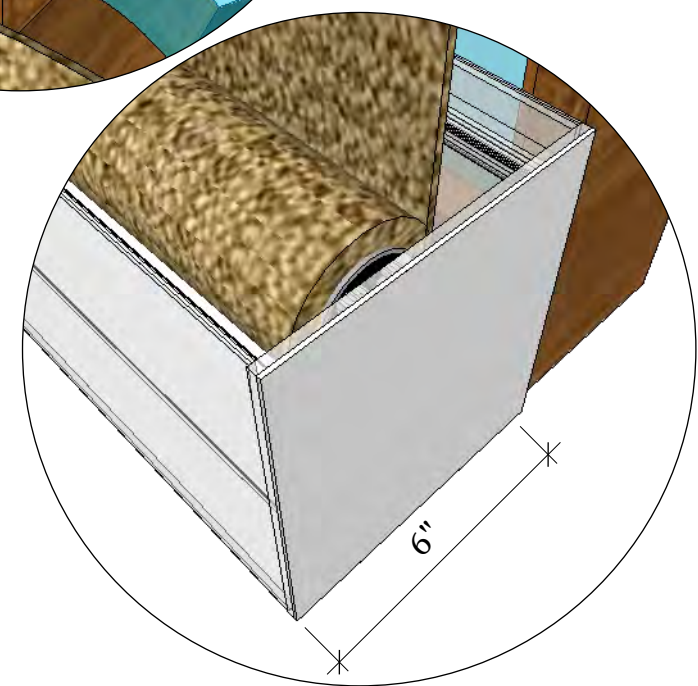
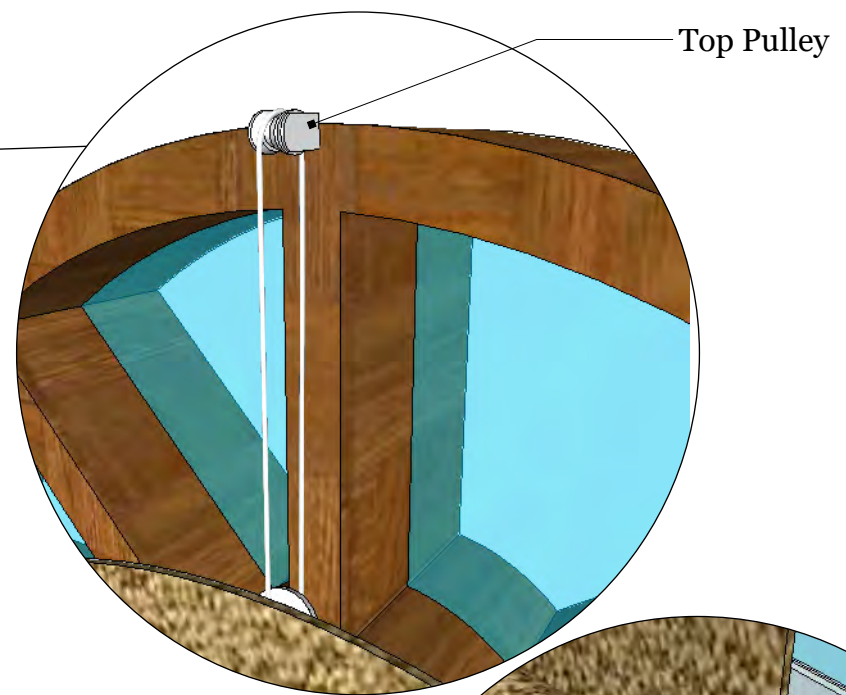
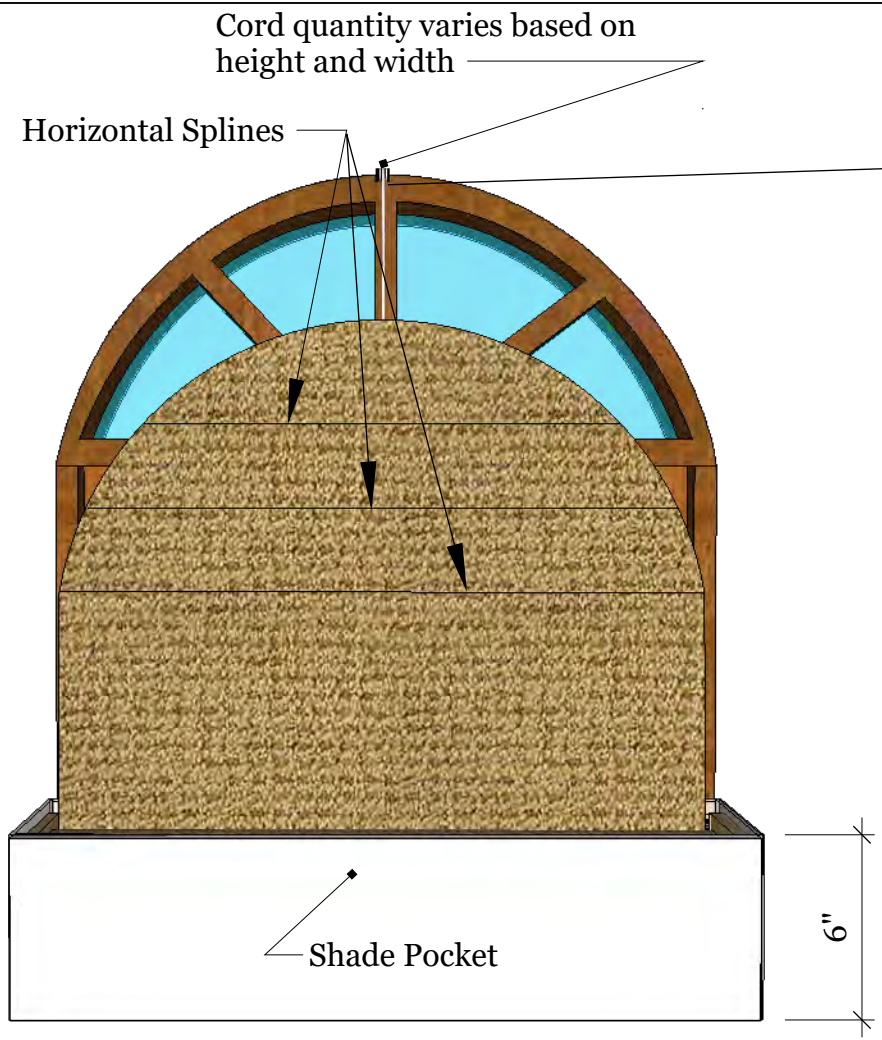

Notes:
 *Standard lift cord color is white. Black is available as custom.
 *Metal colors are white, black, silver, and bronze. Custom color is available upon request.

Bottom-Up Arch Standard



REVISIONS		
	MM/DD/YY	REMARKS
1	--/--/--	...
2	--/--/--	...
3	--/--/--	...
4	--/--/--	...
5	--/--/--	...

A 01

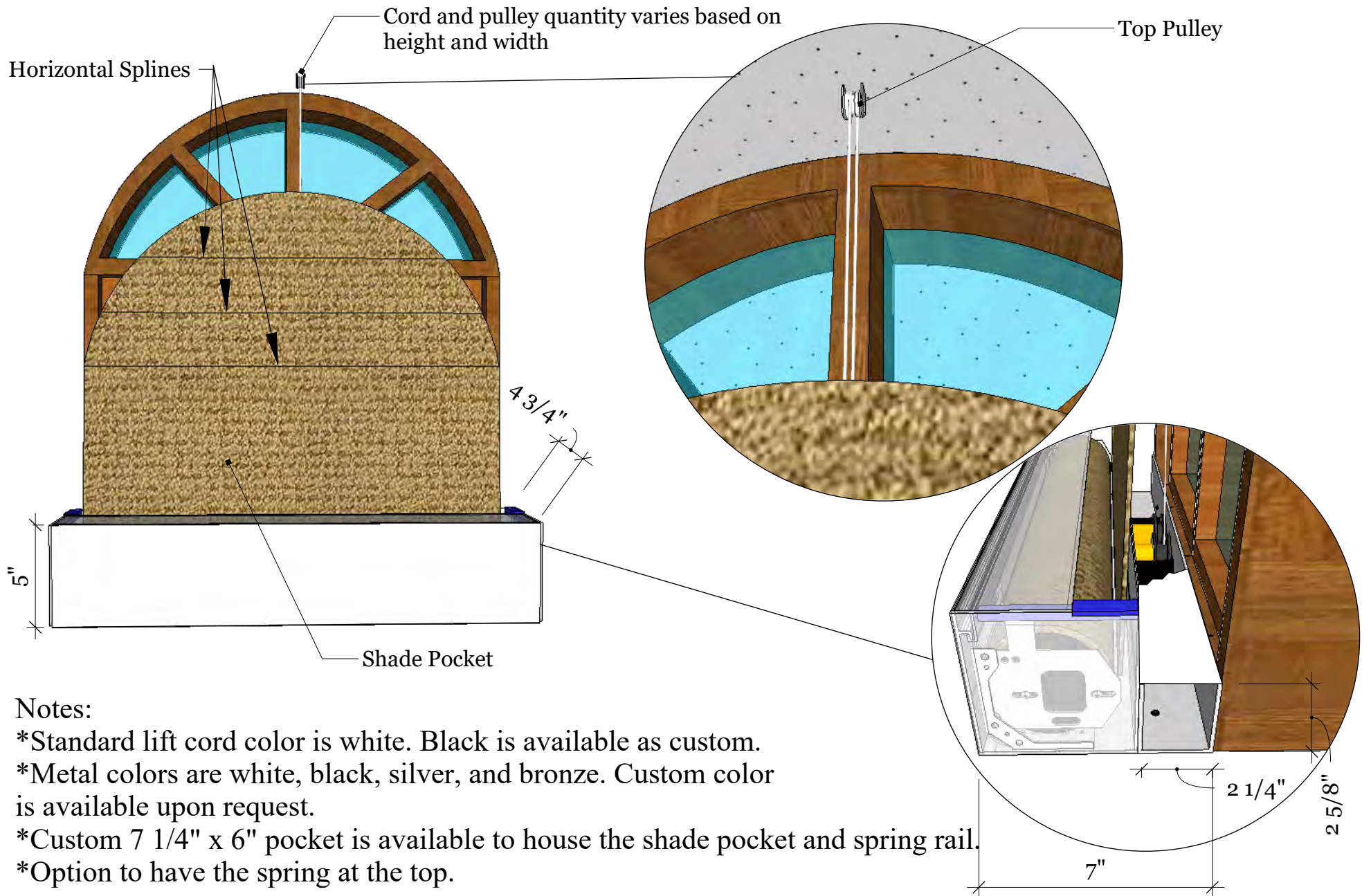

Notes:

- *Standard lift cord color is white. Black is available as custom.
- *Metal colors are white, black, silver, and bronze. Custom color is available upon request.
- *Custom 7 1/4" x 6" pocket is available to house the shade pocket and spring rail.
- *Option to have the spring at the top.

Bottom-Up Arch XL



REVISIONS		
	MM/DD/YY	REMARKS
1	---/---/---	...
2	---/---/---	...
3	---/---/---	...
4	---/---/---	...
5	---/---/---	...

A 01

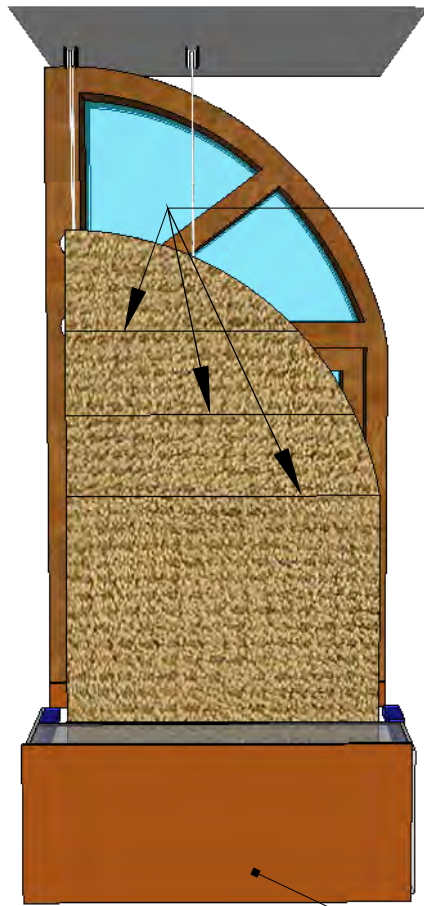

Horizontal Splines
(Quantity and locations
will vary depending
on shade size)

Shade Pocket
(Optional 7 1/4" x 6" pocket shown)

Notes:

*Standard lift cord color is white. Black is available as custom.

*Metal colors are white, black, silver, and bronze. Custom color is available upon request.

*Custom 7 1/4" x 6" pocket is available to house the shade pocket and spring rail.

*Option to have the spring at the top.

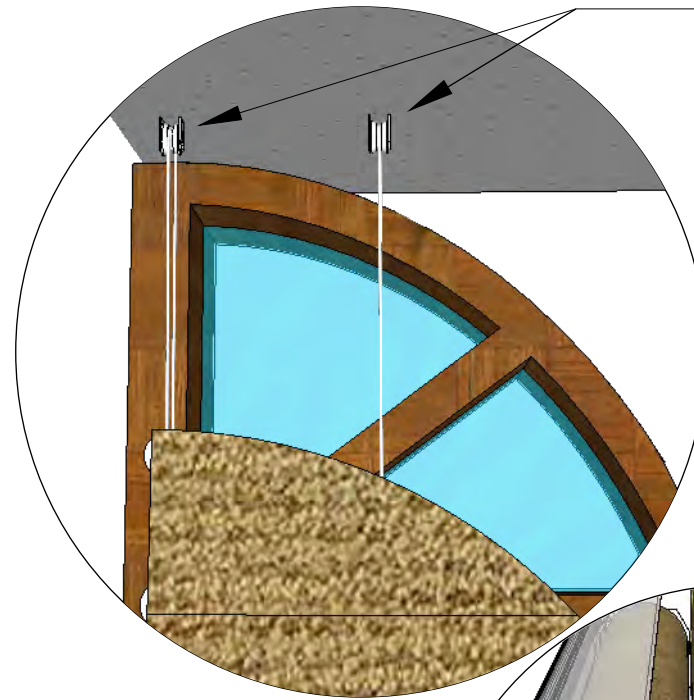

Top Pulley
(Quantity and locations
will vary depending
on shade size)

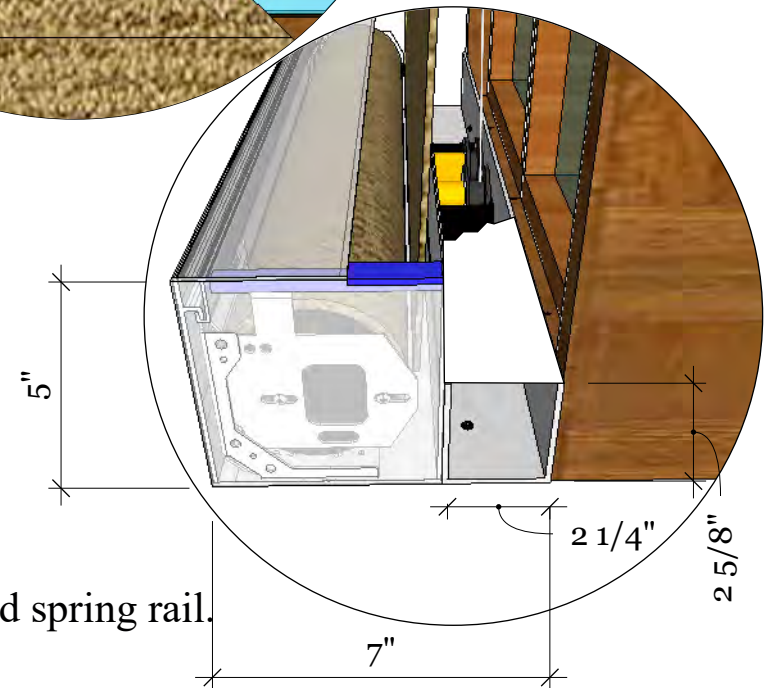

Bottom-Up Quarter Arch XL



REVISIONS

	MM/DD/YY	REMARKS
1	--/--/--	...
2	--/--/--	...
3	--/--/--	...
4	--/--/--	...
5	--/--/--	...

A 01

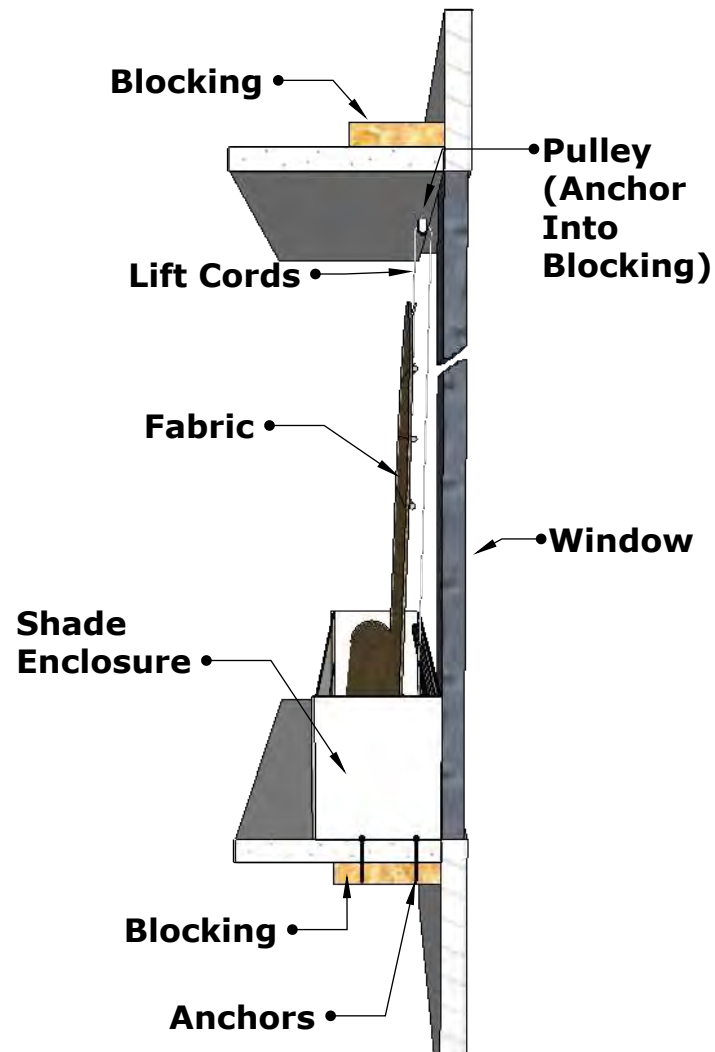

Inside Mount
Typical

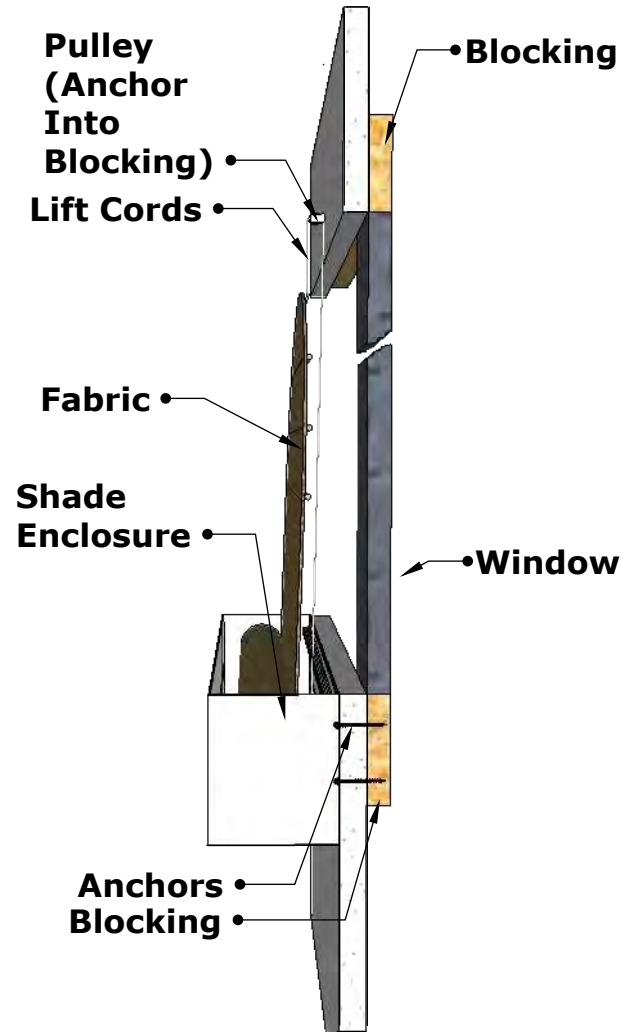

Outside Mount
Typical

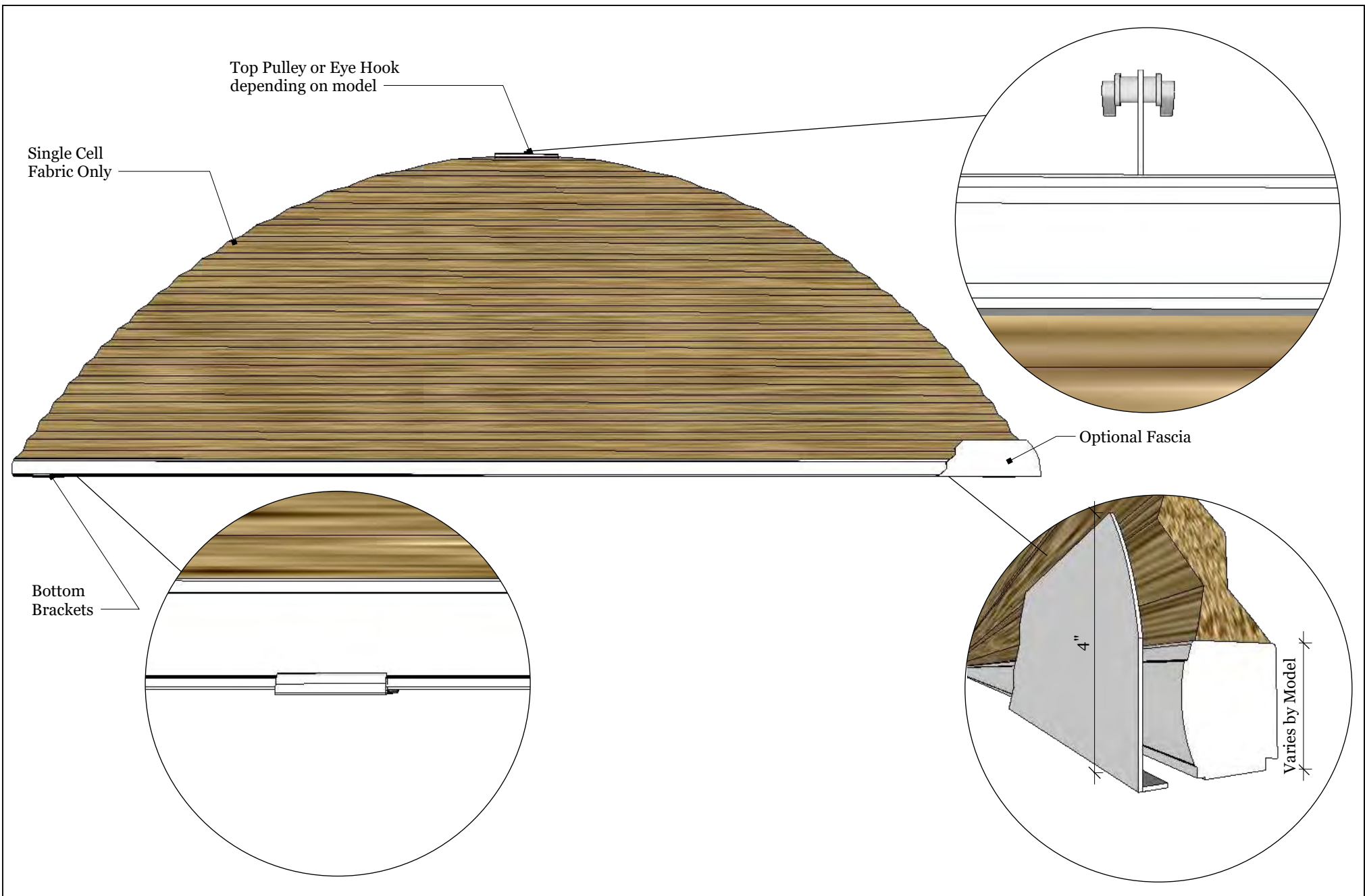

Arched Honeycomb Shades



REVISIONS		
	MM/DD/YY	REMARKS
1	--/--/--	...
2	--/--/--	...
3	--/--/--	...
4	--/--/--	...
5	--/--/--	...

A 01

ROMAN AND WOVEN SHADES



Roman shades are constructed using fabric and woven wood materials to provide a fluid, sculpted, soft line to accent any décor. They are available in an abundance of styles, pleats, and patterns. Roman shade materials are available in fabric, faux, grass, wood, bamboo, thatch, and natural fibers.

Design Options



Flat Roman
With Fabric Front No Valance

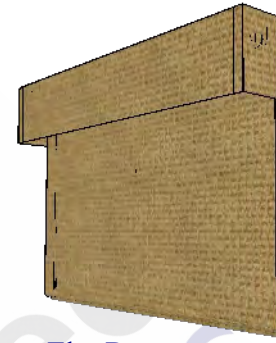

Flat Roman
With Fabric Back Valance Front



Hobbled Roman
With Fabric Front No Valance

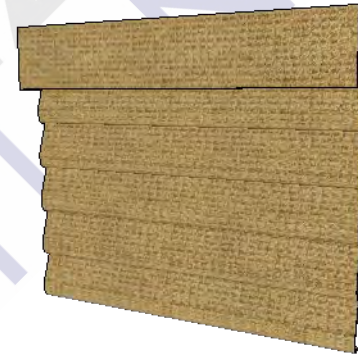

Hobbled Roman
With Fabric Back Valance Front

Note: Additional Roman styles are available including Austrian, Ribbed Front, and Soft Roman. Please send a picture of the Roman style you would like fabricated to our sales team for a custom quote.

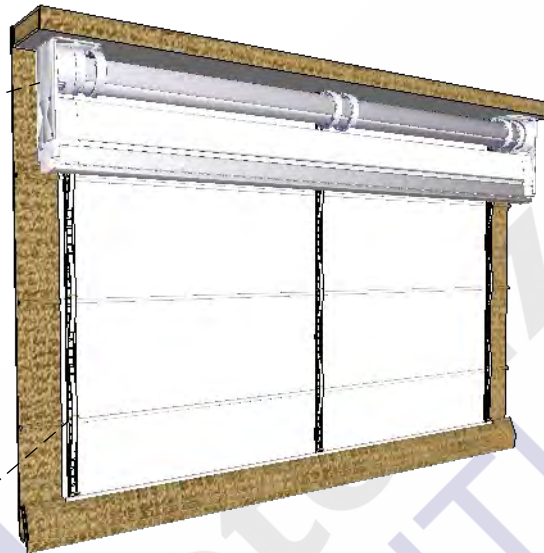
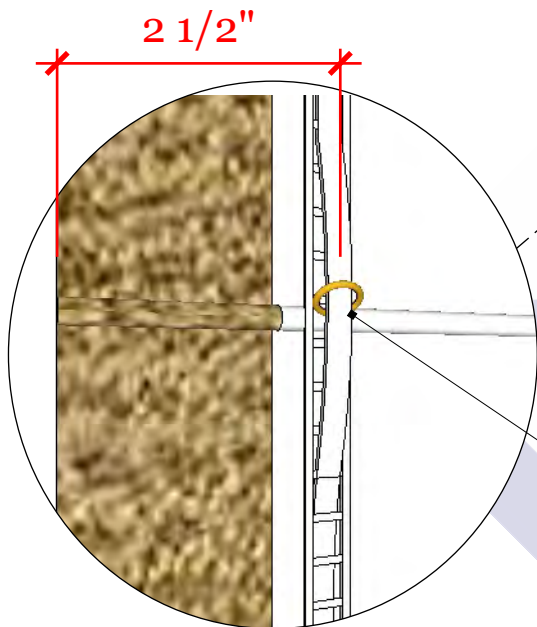
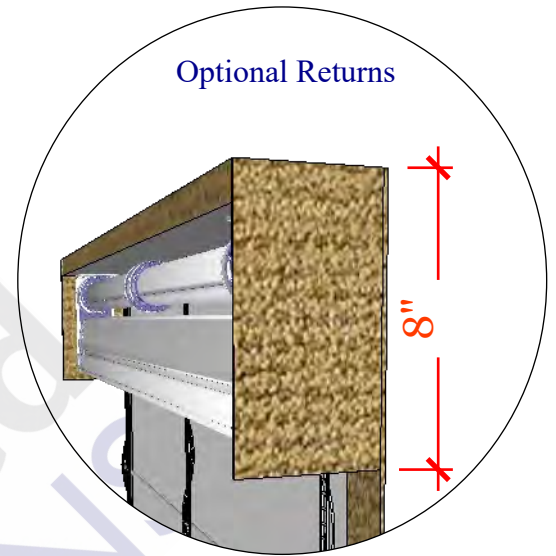
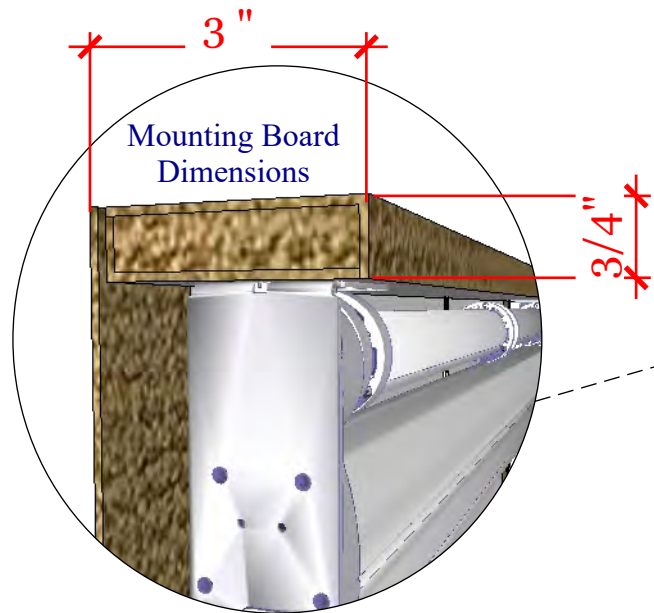

Lutron recommends a space of 1" between the edge of the shade and beginning of the motorized assembly at each end.

The first set of rings are to be placed a minimum of 2 1/2" from each end.

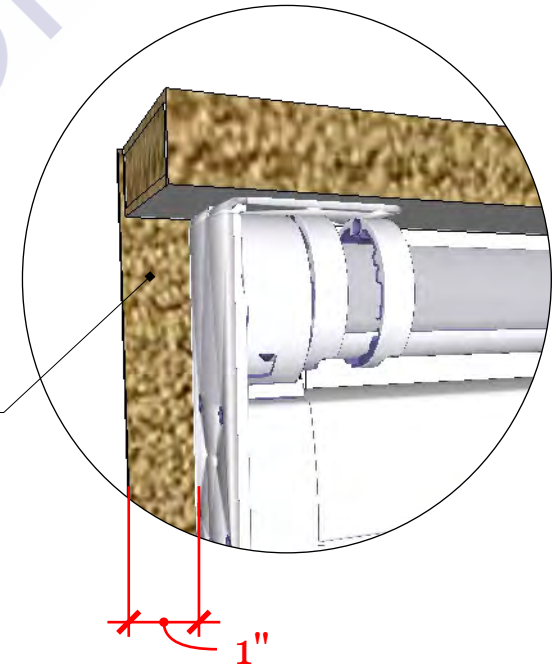

Triathlon Detail
(Flat Roman Fabric Front Depicted)

Motorized
SOLUTIONS
866-446-6867

REVISIONS

	MM/DD/YY	REMARKS
1	---/---/---	...
2	---/---/---	...
3	---/---/---	...
4	---/---/---	...
5	---/---/---	...

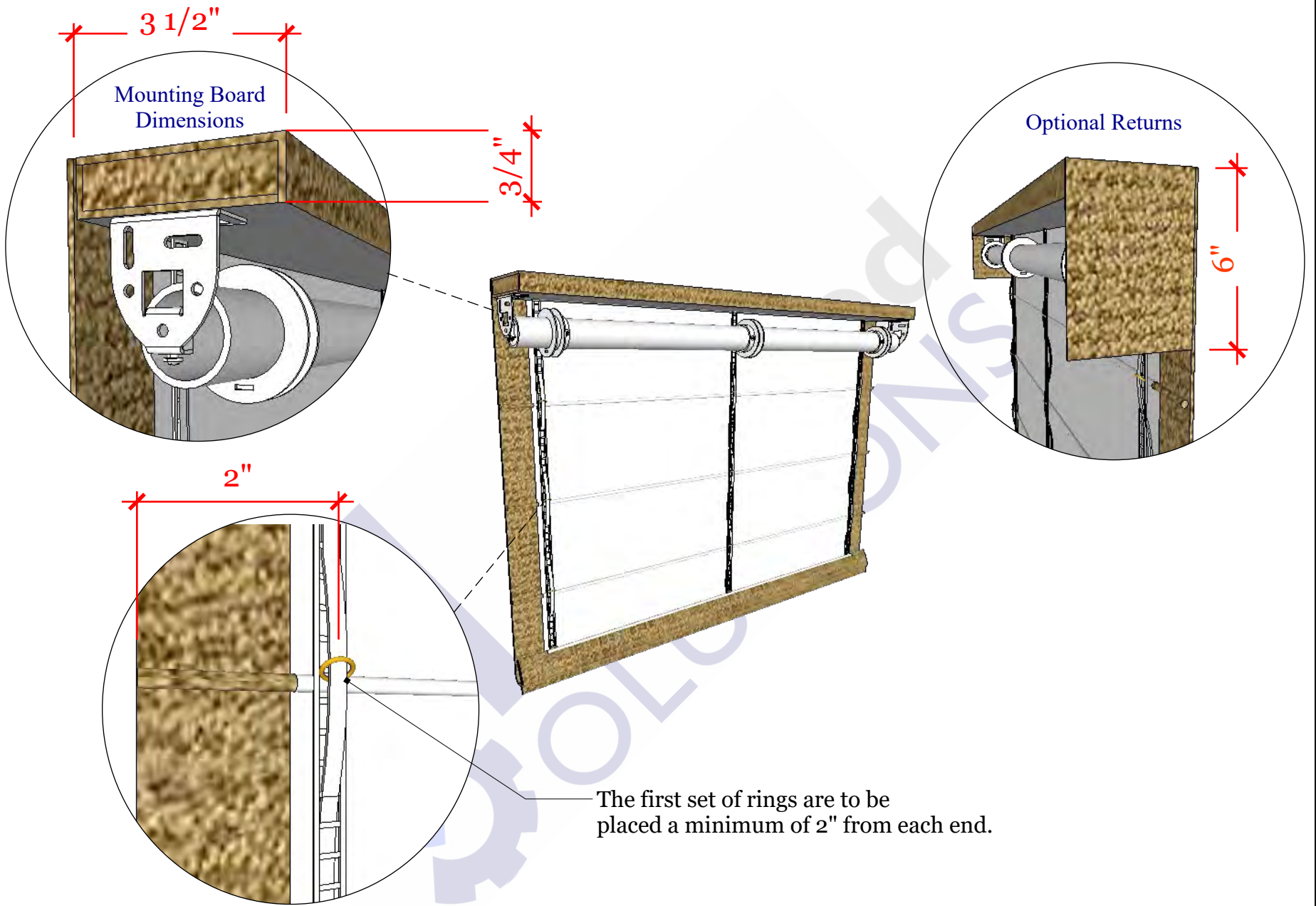

Roller 64 Detail
 (Flat Roman Fabric Front Depicted)



REVISIONS		
	MM/DD/YY	REMARKS
1	---/---/---	...
2	---/---/---	...
3	---/---/---	...
4	---/---/---	...
5	---/---/---	...

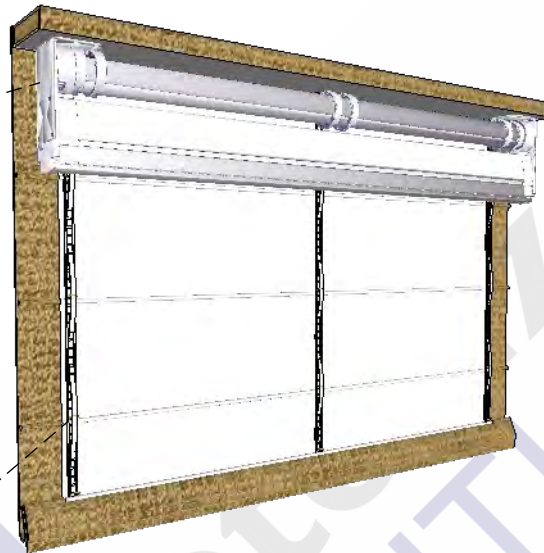
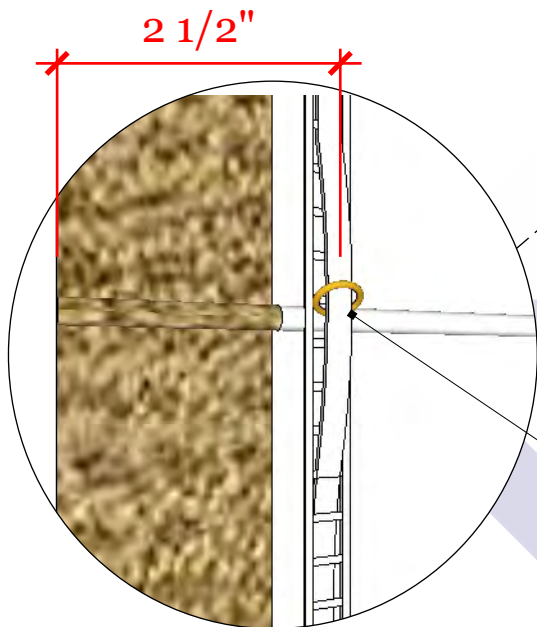
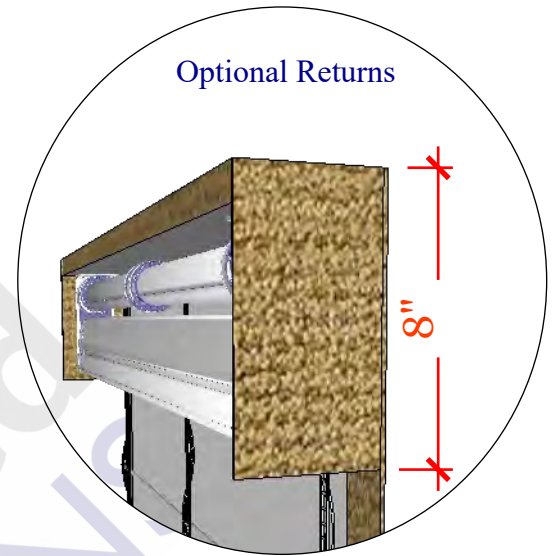
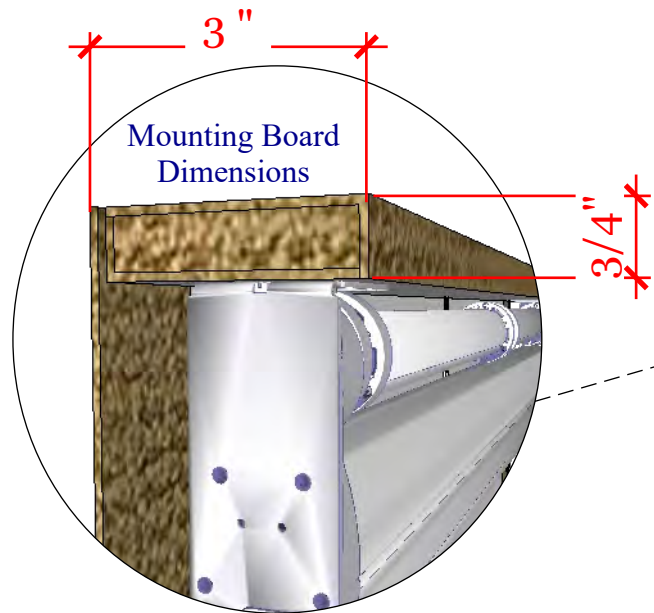

Lutron recommends a space of 1" between the edge of the shade and beginning of the motorized assembly at each end.

The first set of rings are to be placed a minimum of 2 1/2" from each end.

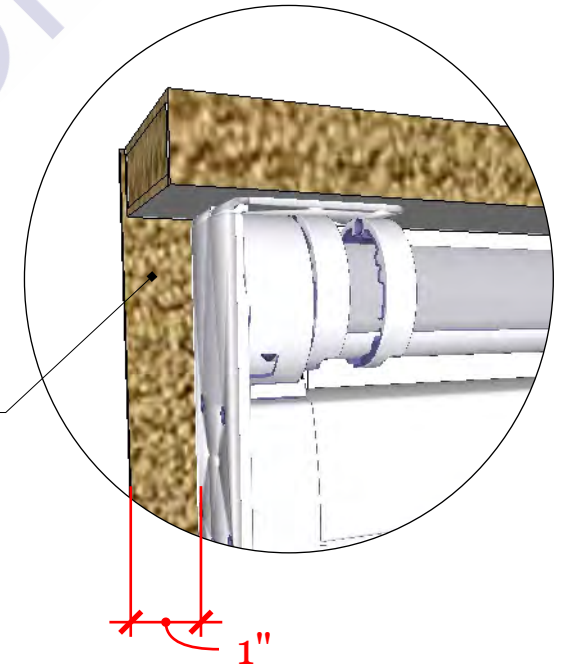

Triathlon Detail
(Flat Roman Fabric Front Depicted)

Motorized
SOLUTIONS
866-446-6867

REVISIONS

	MM/DD/YY	REMARKS
1	---/---/---	...
2	---/---/---	...
3	---/---/---	...
4	---/---/---	...
5	---/---/---	...

DRAPERIES TRACKS



Draperies provide a timeless solution for your window covering requirements. They offer a soft, decorative accent to your room. Draperies are available in an endless variety of fabric designs and opacities. From heavier materials that offer an insulation value to sheer fabrics that gently reduce the ambient light, there is a drapery fabric that will meet your design needs.

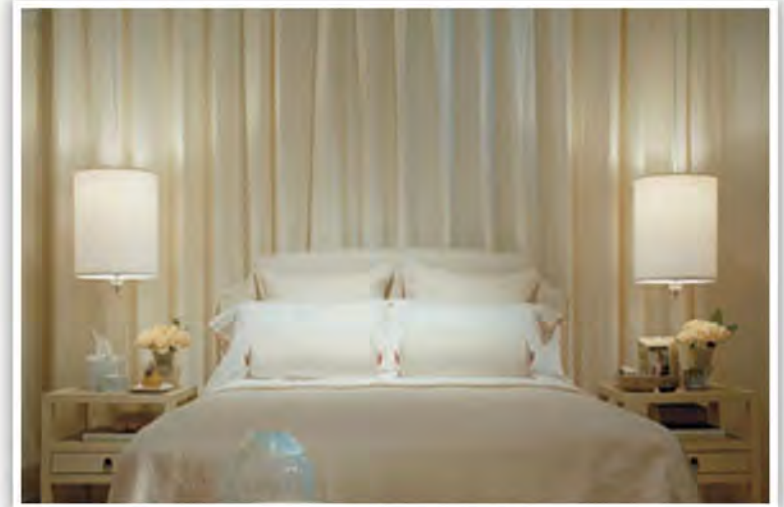



Front view (single track, right draw)

Track width 18 ft (5.5 m) max without splice
 Up to 30 ft (9.1 m) with splice (2 splice max)

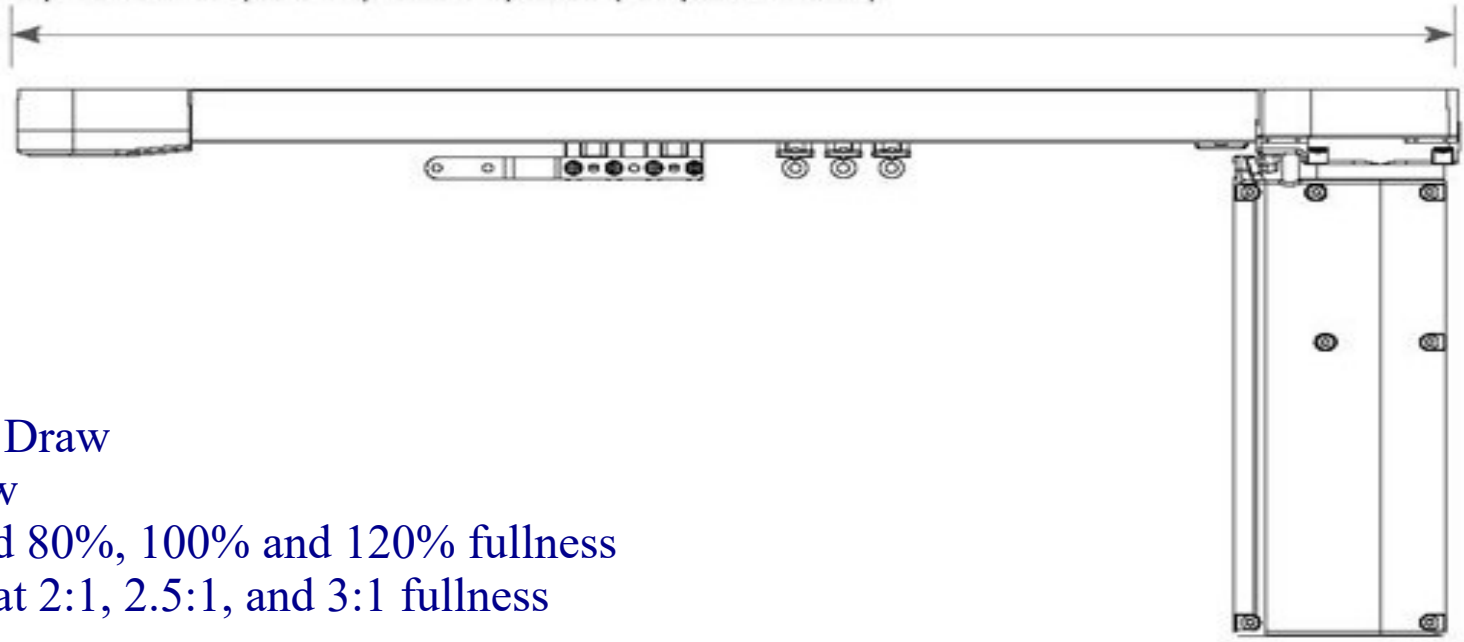

Options:

- *One Way Draw
- *Split Draw
- *Ripplefold 80%, 100% and 120% fullness
- *Pinch Pleat 2:1, 2.5:1, and 3:1 fullness

Drapery Tracks



REVISIONS		
	MM/DD/YY	REMARKS
1	--/--/--	...
2	--/--/--	...
3	--/--/--	...
4	--/--/--	...
5	--/--/--	...

A 01

PerfectFit





Introducing the Motorized Solutions Perfect Fit series.

Perfect Fit takes a holistic approach to window treatment concealment. If attention to detail is your pursuit, then Perfect Fit is your solution!



Mud in Solutions for Roller Shades



The Perfect Fit Mud in Solutions for Roller Shades system has been designed to finish the edges of a custom pocket application.



Install Shades to Perfection in Minutes

- The integrated bracket eliminates the need to install the shade bracket.
- No leveling of hangers to match ceiling line. The hanger is integrated into the pocket extrusion.
- Mud in Pocket pre-made Inside and Outside corners connect, and are seamless once mud in.
- Mud in End Caps ensure every opening is finished square.

Easily cut and trim the pocket with a standard miter saw

- Mud in Pocket was designed modular, allowing the pocket to be disassembled so that it can be cut without the need of a large saw.

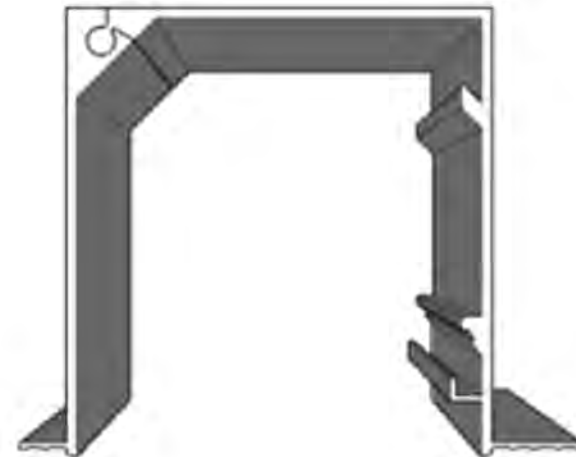

Mud In Pocket

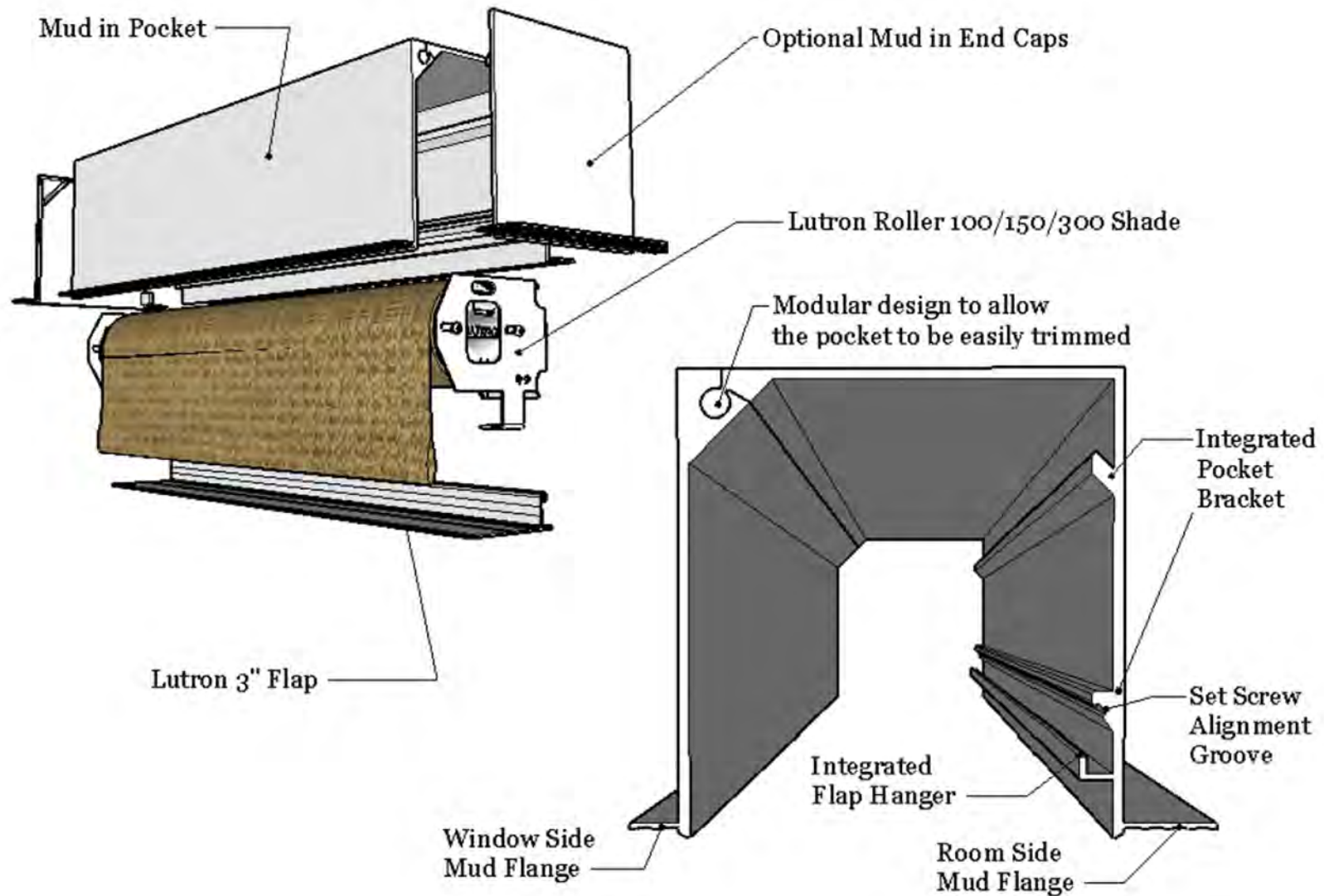

Mud In Pocket

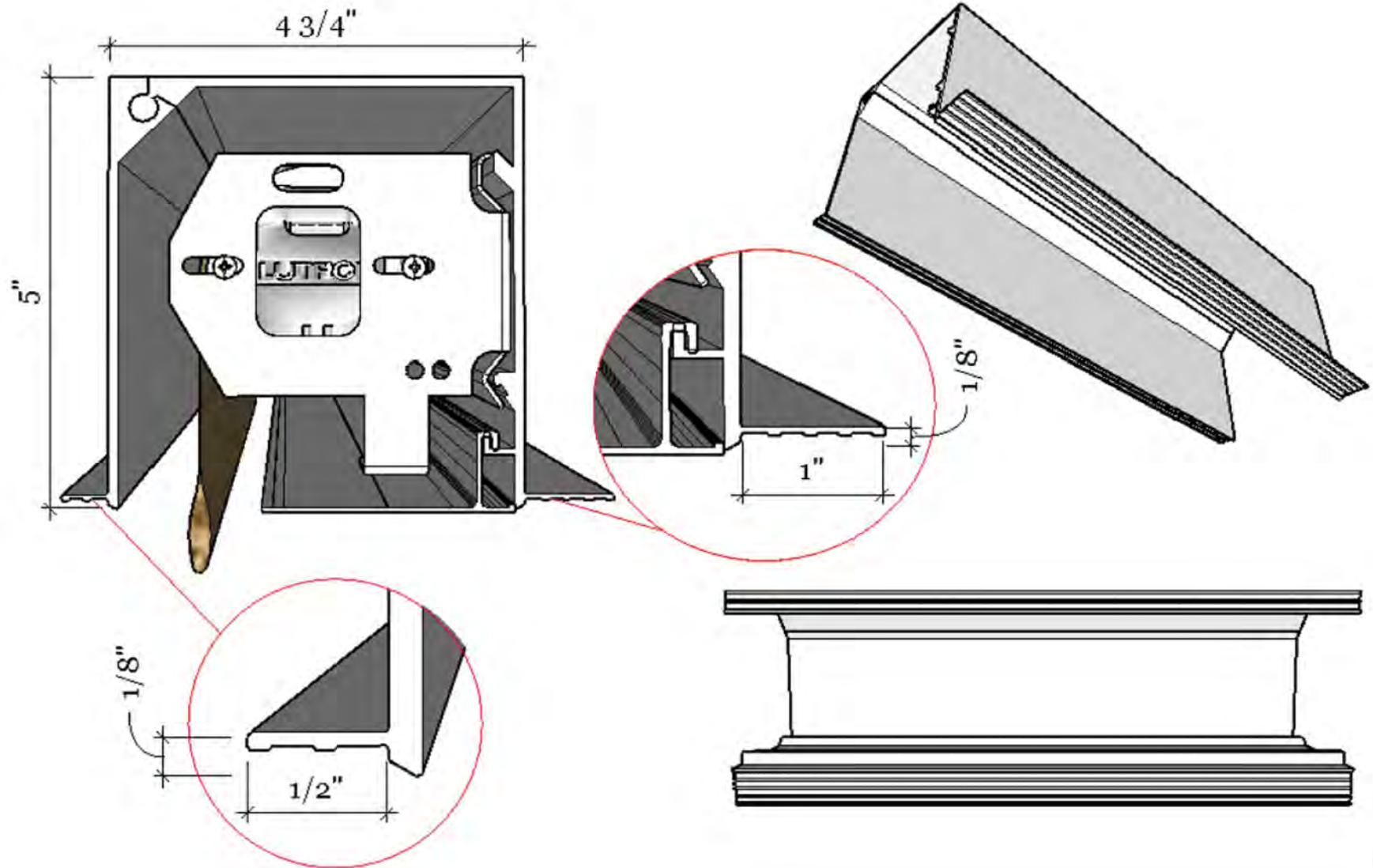

Reduce Installation Time!

- You are guaranteed to have the proper depth using the Perfect Fit MIH corners
- No leveling of hanger
 - The hanger is installed during construction. Simply hook on the flap
- No more mitering or feathering of the flap at the corners to compensate for out of square cavities
 - By using the Perfect Fit MIH corner, you are guaranteed a perfectly square edge
- By having the builder construct the cavity with solid plywood or MDF along the top, simple wood screws can be used to anchor the shade brackets, eliminating the possibility of blocking not being in place

Various sizes available

- MIH connects together to seamlessly form any width.
- The hanger is designed for Lutron 2", 3", and 5" flap
- The corners are available in 3.5", 4.75", 6", and 7" depths
(custom sizes are available upon request)

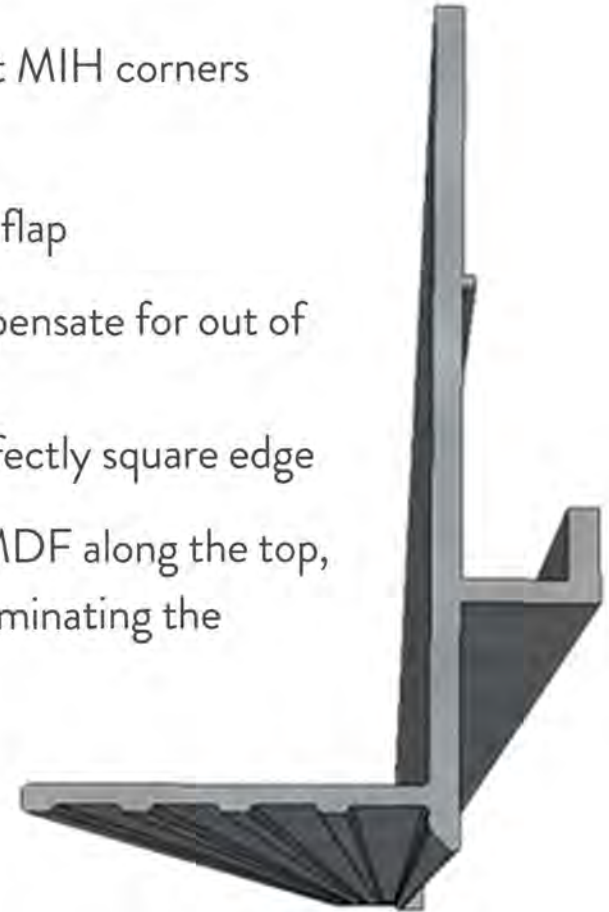

Mud In Hanger

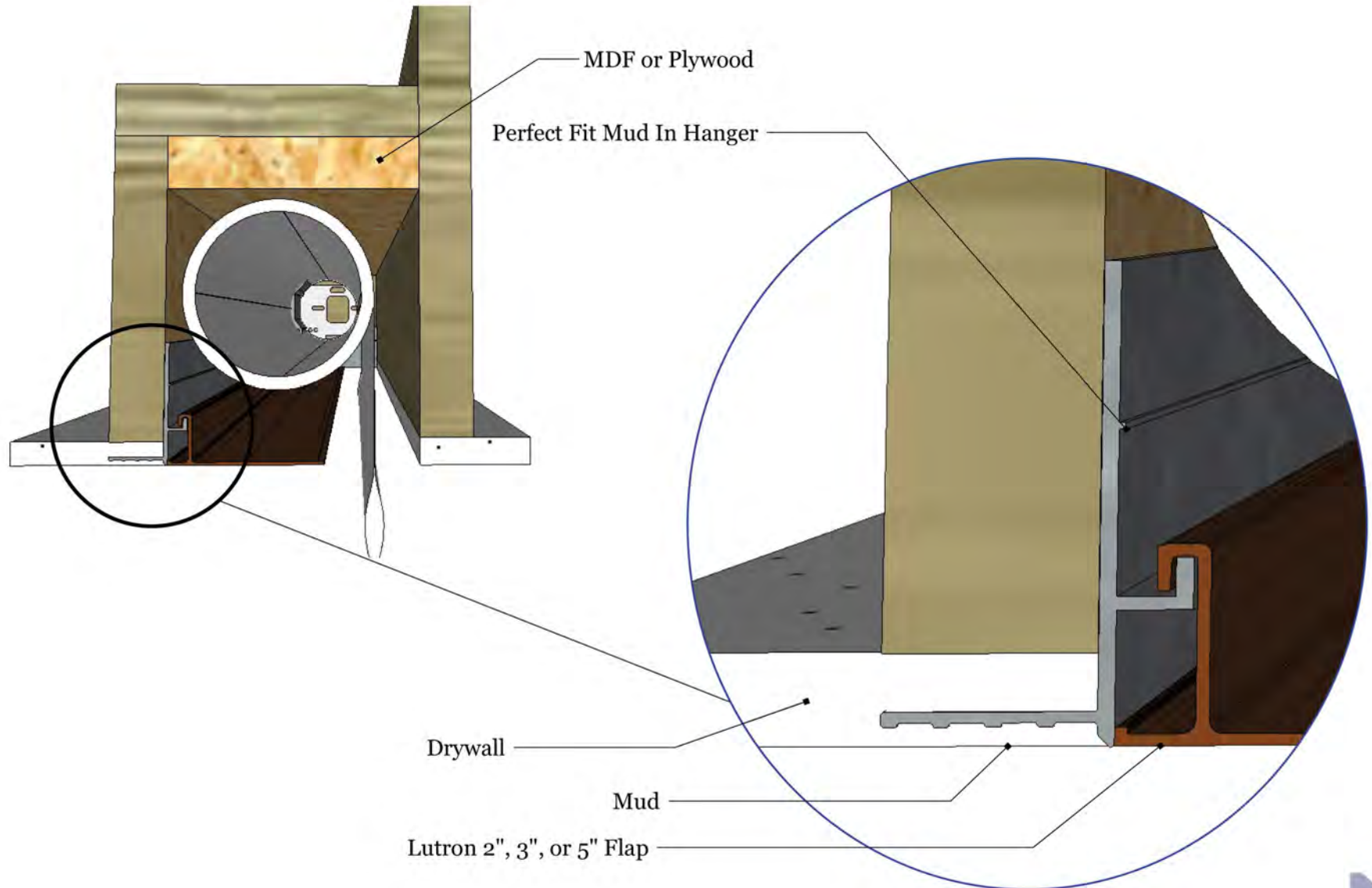

DTC has been engineered for function.

The system provides a perfectly contoured recess for your motorized drapery track and allows for a true, uninterrupted, floor-to-ceiling drapery.



Recessed Drapery Track Cavity

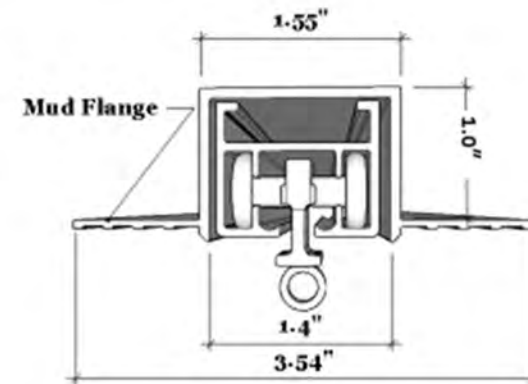
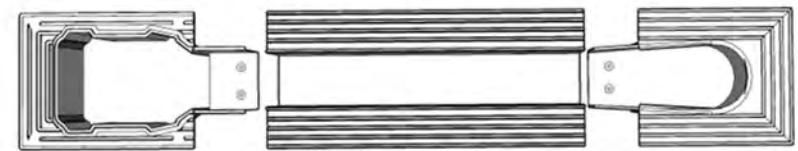
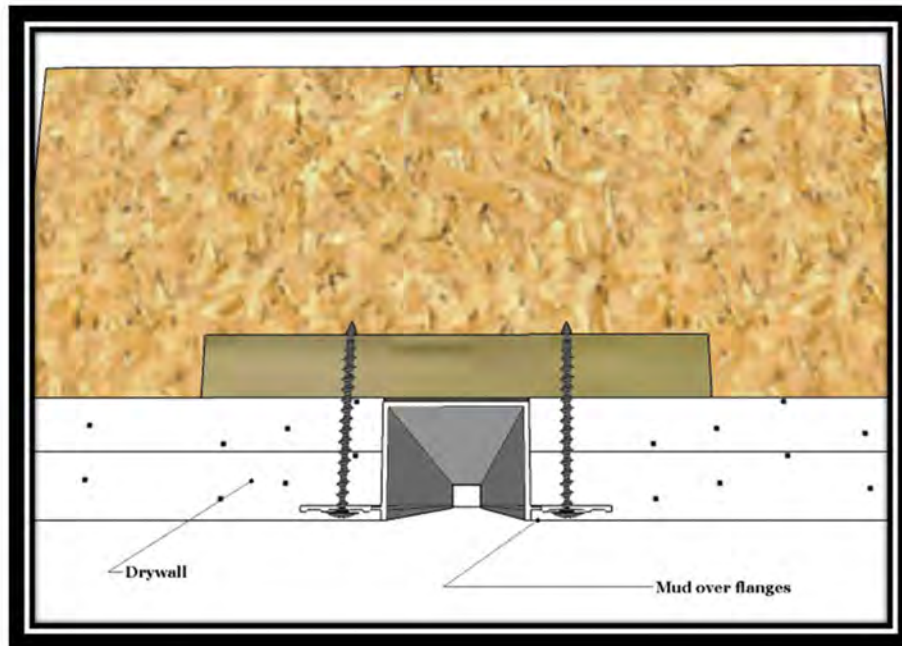

MOTORIZED SOLUTIONS PARTS: MUD IN POCKET



Perfect Fit
Mud in Pocket



*A mud in pocket system with integrated bracket. Mud in Pocket ensures a clean transition from the drywall ceiling edge to the shade cavity.

Perfect Fit
Mud in Pocket End Cap



*A mud in end cap for the Mud in Pocket system.

Perfect Fit
Mud in Pocket Regular Roll
Inside Corner or Reversed Roll Outside Corner



*A perfect 90 degree inside corner used where shades meet, eliminating the need to miter the pocket.

Perfect Fit
Mud in Pocket Reversed Roll
Inside Corner or Regular Roll Outside Corner

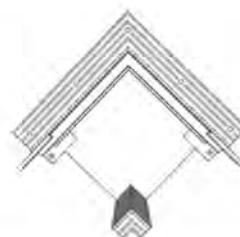

*A perfect 90 degree outside corner used where shades meet, eliminating the need to miter the pocket.

MOTORIZED SOLUTIONS PARTS: MUD IN HANGER



Perfect Fit
Mud In Hanger (accepts flap)



*Creates a perfectly clean line when recessing shades into the ceiling. Eliminates the need for pocket or flap/hanger

Perfect Fit
Mud In Hanger corner



*A perfect 90 degree corner when combined with the above product

Perfect Fit
Mud In Hanger Inside and
Outside Corners

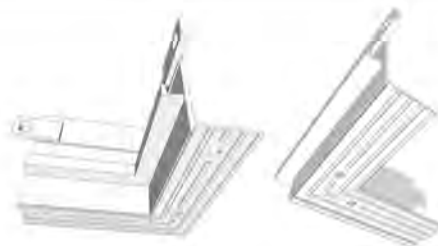

*Shades butting in a corner? Create a Perfect Fit intersection without the need to miter pockets using these components.

MOTORIZED SOLUTIONS PARTS: MUD IN DRAPERY TRACK CAVITY



Perfect Fit
Recessed Drapery Track Cavity

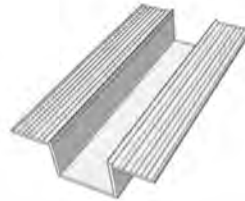

*Seamlessly allows drapery tracks to be recessed into the ceiling

Perfect Fit
Recessed Drapery Track Ends

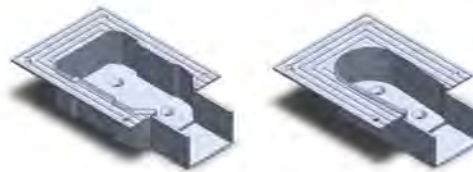

*Motor and idle end for the above

Perfect Fit
Recessed Drapery Track Cavity Bend



*Radius bend for recessed cavity

Perfect Fit
Bendable Drapery Track Cavity

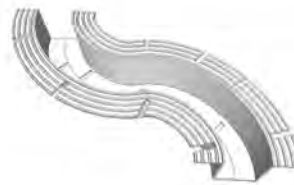

*This is a two-piece bendable Perfect Fit cavity that allows you to create custom curves and bends

MOTORIZED SOLUTIONS PARTS: INSTALLATION TOOLS



Perfect Fit
Centering Tool



*This tool is used to help center Lutron drapery tracks

Perfect Fit
Dimension Tool



*This tool is used when installing custom curved Perfect Fit cavities to ensure proper spacing for the track.

Perfect Fit
Mud in Pocket Drilling Guide

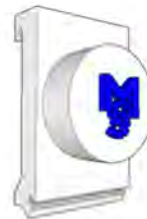

*The Mud in Pocket Drilling Guide ensures the proper angle when drilling the pilot hole for the bracket set screw.

MOTORIZED SOLUTIONS PARTS: MISCELLANEOUS



Bottom-up flap support



*Supports the pocket flap in bottom-up applications

Compresso



Compresso condensed space dual bracket allows a dual Lutron roller 100/150/300 shade to fit in a 6.5" X 9" pocket.

Spring assembly



*Constant tension spring units

Spring assembly pocket



*Pocket for the above

MOTORIZED SOLUTIONS PARTS: MISCELLANEOUS



Bottom-up side channel transition



*Allows the fabric to transition out of the pocket and into the side channel on bottom-up applications

Roman shade tape reel for roller 64 and 100 tube



*Tape and safety shroud is also available

Manual drapery track



*Manual track for pinch pleat and Ripplefold draperies that closely matches the Lutron drapery track form.



Our MISSION

Motorized Solutions is committed to providing our clients with the most innovative, high-quality automated window treatments in the industry, coupled with a superior customer service experience.

- We are guided by core values that are shared by every member of our team
- We are dedicated to building long-term client relationships
- We will help inspire, educate, and problem solve for our clients
- We value the trust our clients have placed in us and continuously strive to exceed their expectations

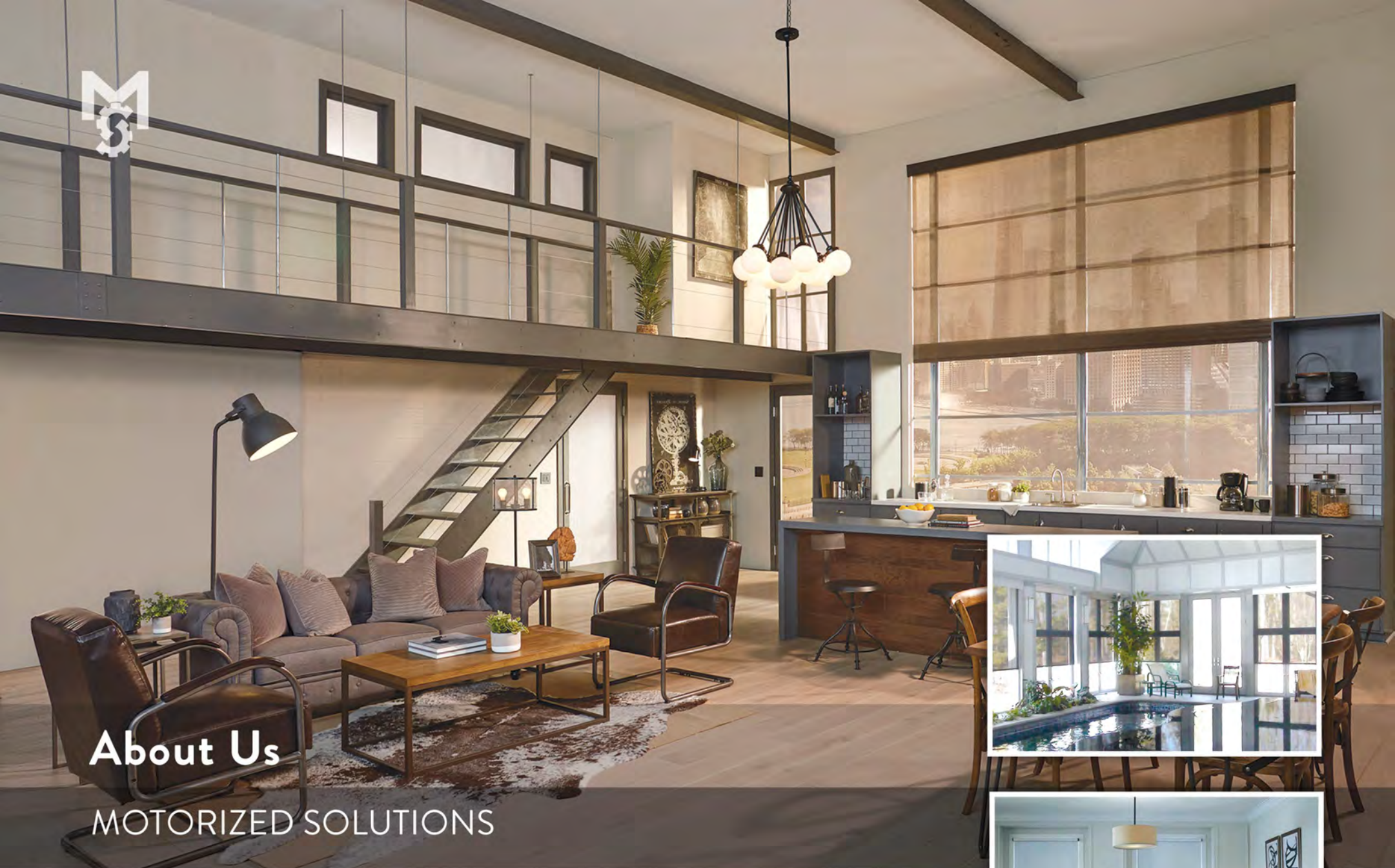

About Us

MOTORIZED SOLUTIONS

Motorized Solutions is proud to offer the most innovative window treatments in the industry since 1976.

Founded in the 1940's as an exclusive custom upholstery company, we have the ingrained passion to perform each project with precision. Our strive for perfection has enabled us to become Lutron's premier residential dealer and the first window treatment dealer inducted into the Lutron Hall of Fame.

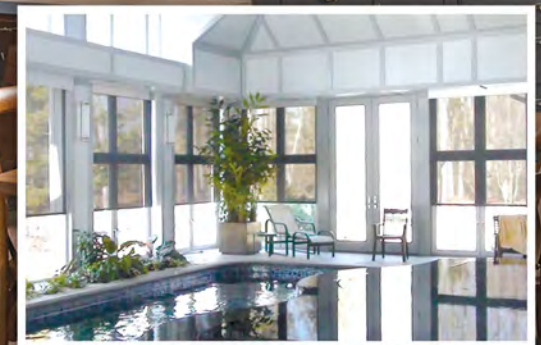

Innovations

IN MOTORIZED SOLUTIONS



Motorized Solutions®

Toll Free: 866.446.6867

motorizedsolutions.com

info@motorizedsolutions.com